

ELEN 326

Differential Pairs

Dr. Aydın İlker Karşilayan

Texas A&M University
Department of Electrical Engineering

Emitter-Coupled Pair

DC transfer

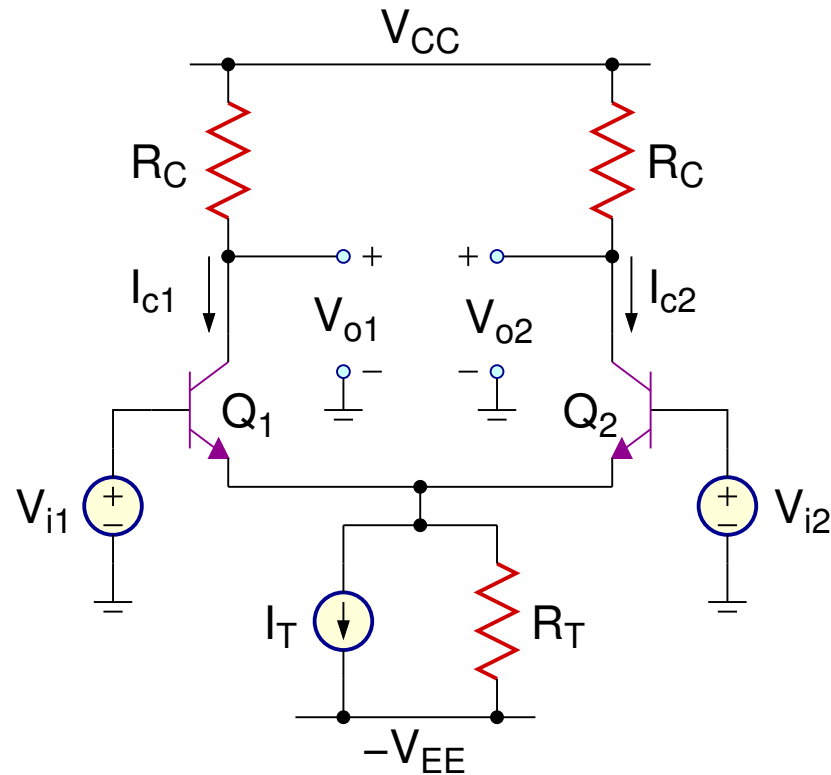

$$V_{i1} - V_{be1} + V_{be2} - V_{i2} = 0$$

$$V_{be1} = V_T \ln \frac{I_{c1}}{I_{S1}} \quad , \quad V_{be2} = V_T \ln \frac{I_{c2}}{I_{S2}}$$

$$\frac{I_{c1}}{I_{c2}} = \exp\left(\frac{V_{be1} - V_{be2}}{V_T}\right) = \exp\left(\frac{V_{i1} - V_{i2}}{V_T}\right) = \exp\left(\frac{V_{id}}{V_T}\right)$$

$$I_{c1} + I_{c2} = \alpha I_T$$

$$I_{c1} = \frac{\alpha I_T}{1 + \exp\left(-\frac{V_{id}}{V_T}\right)}, \quad I_{c2} = \frac{\alpha I_T}{1 + \exp\left(\frac{V_{id}}{V_T}\right)}$$

$$V_{o1} = V_{CC} - I_{c1}R_C \quad V_{o2} = V_{CC} - I_{c2}R_C$$

$$V_{od} = V_{o1} - V_{o2} = \alpha I_T R_C \tanh\left(-\frac{V_{id}}{2V_T}\right)$$

Emitter-Coupled Pair

DC transfer

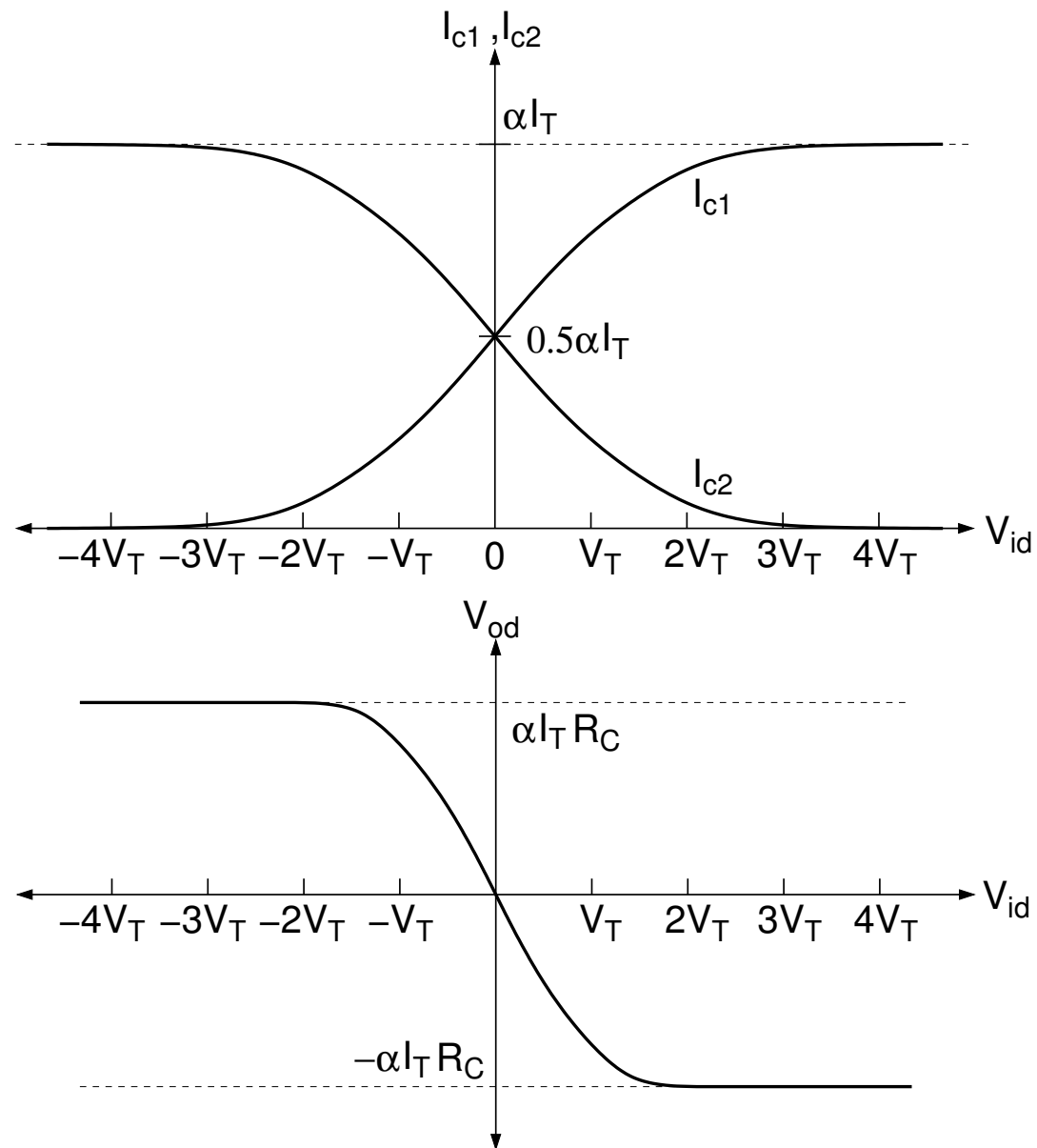

Emitter-Coupled Pair

Emitter degeneration

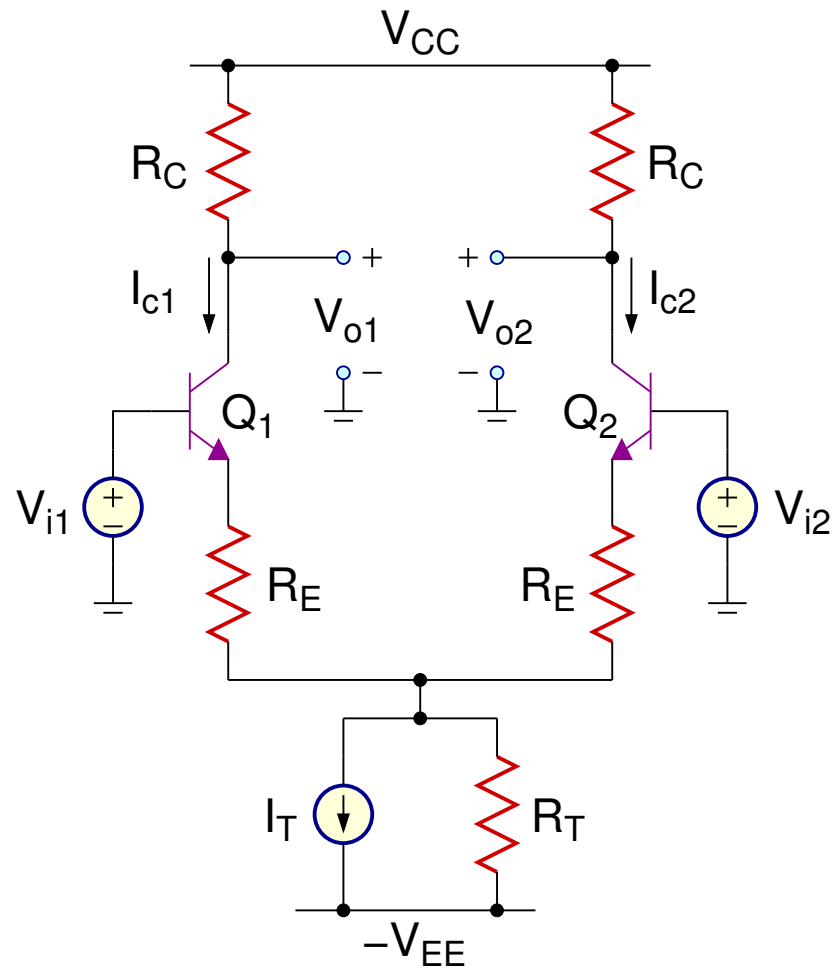

Emitter-Coupled Pair

Emitter degeneration

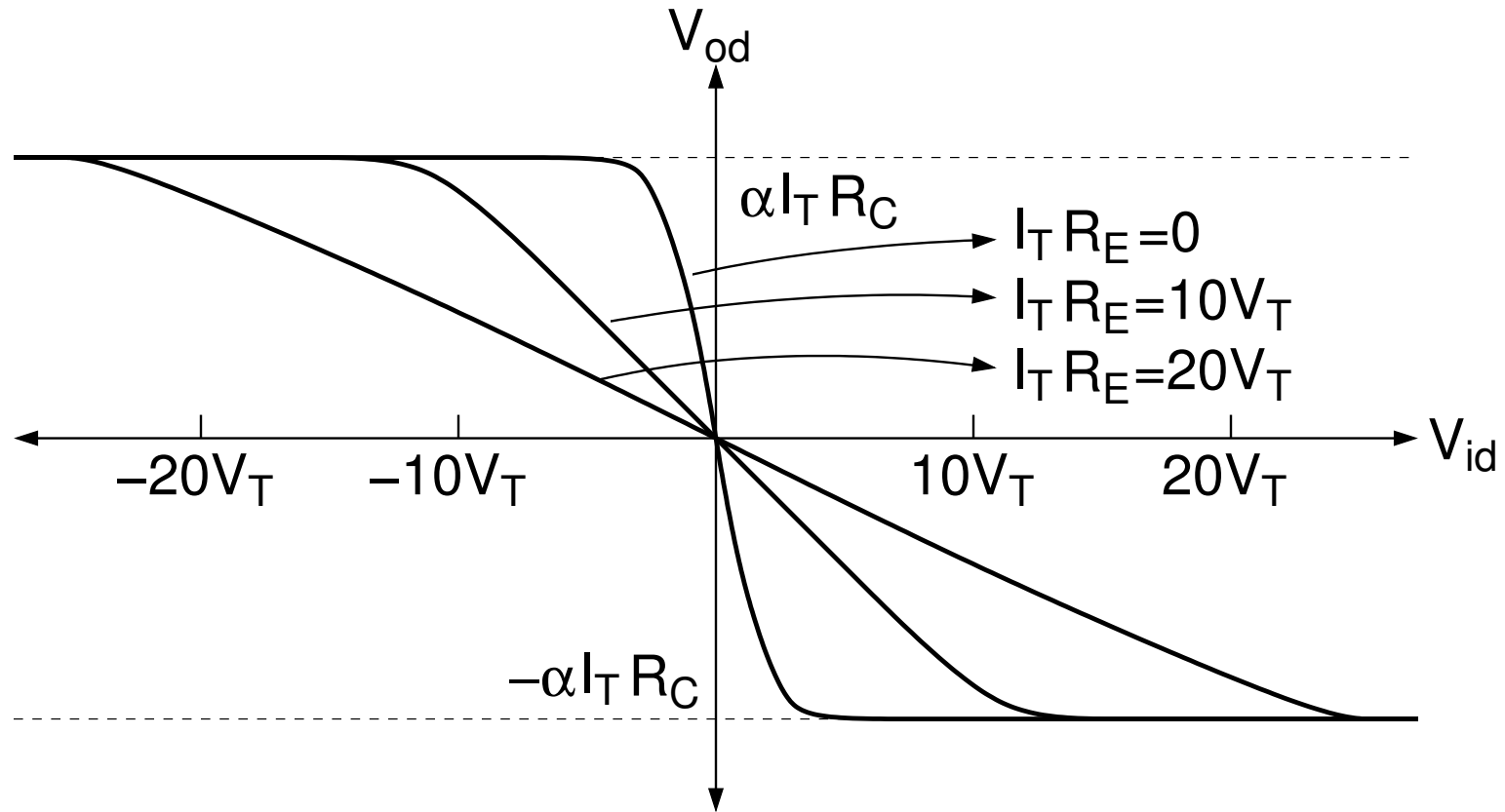

Source-Coupled Pair

DC transfer

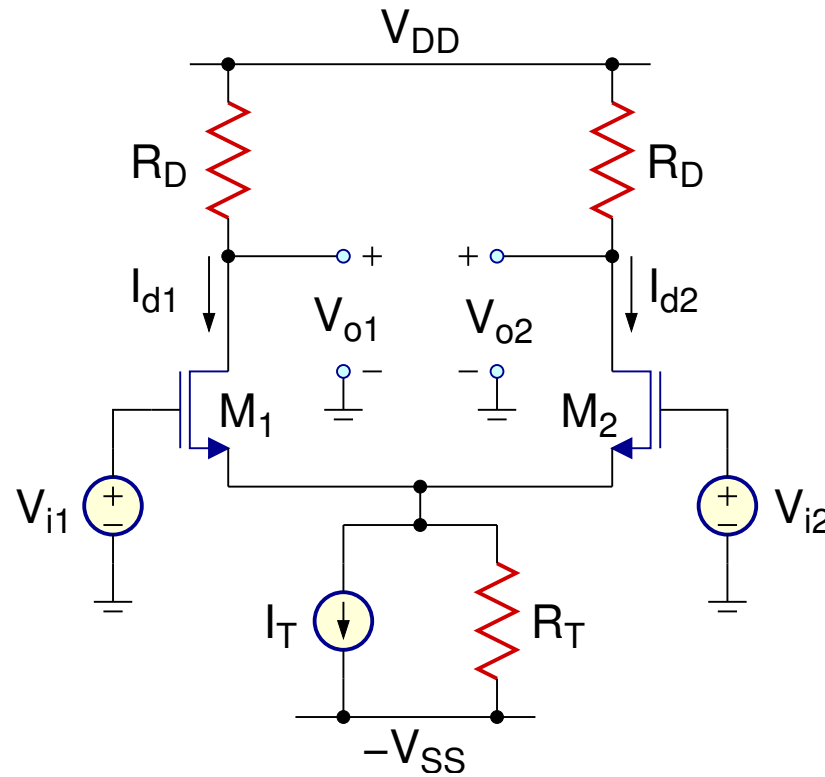

$$V_{i1} - V_{gs1} + V_{gs2} - V_{i2} = 0$$

$$V_{gs1} = V_t + \sqrt{\frac{I_{d1}}{\frac{k' W}{2 L}}}, \quad V_{gs2} = V_t + \sqrt{\frac{I_{d2}}{\frac{k' W}{2 L}}}$$

$$I_{d1} + I_{d2} = I_T$$

$$V_{id} = V_{i1} - V_{i2} = V_{gs1} - V_{gs2} = \frac{\sqrt{I_{d1}} - \sqrt{I_{d2}}}{\sqrt{\frac{k' W}{2 L}}}$$

$$I_{d1} = \frac{I_T}{2} + \frac{k' W}{4 L} V_{id} \sqrt{\frac{4 I_T}{k' (W/L)} - V_{id}^2}$$

$$I_{d2} = \frac{I_T}{2} - \frac{k' W}{4 L} V_{id} \sqrt{\frac{4 I_T}{k' (W/L)} - V_{id}^2}$$

Both transistors operate in the active region if

$$|V_{id}| \leq \sqrt{\frac{2 I_T}{k' (W/L)}} = \sqrt{2} V_{ov}|_{V_{id}=0}$$

Source-Coupled Pair

DC transfer

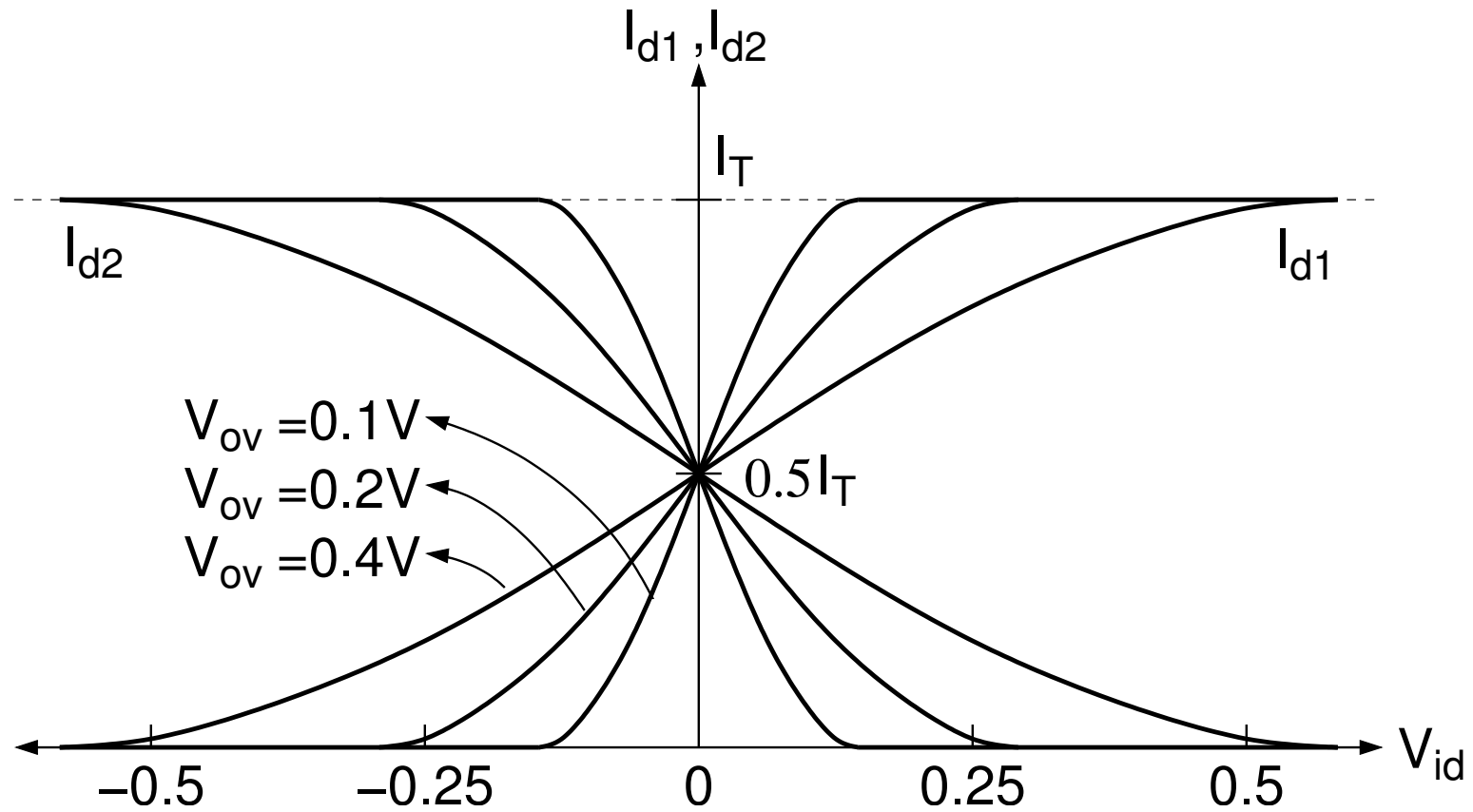

Differential Pairs

Small-signal analysis

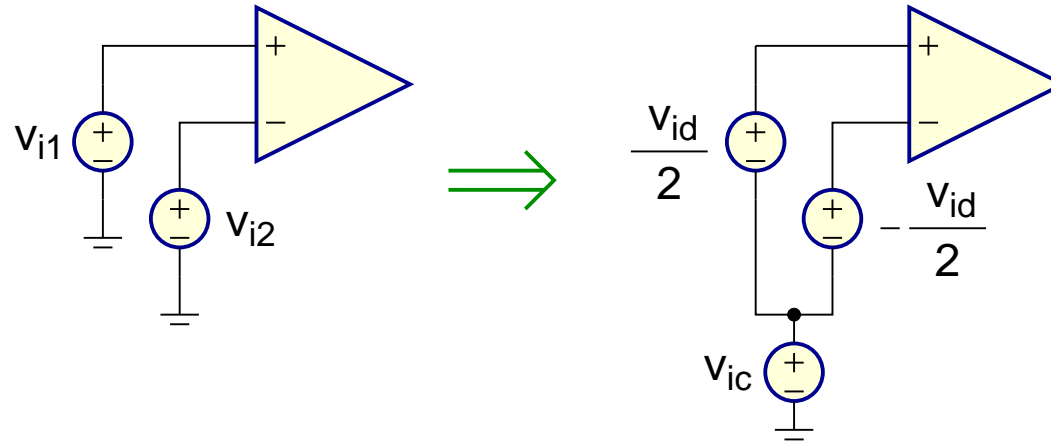

$$V_{id} = V_{i1} - V_{i2}$$

$$V_{ic} = \frac{V_{i1} + V_{i2}}{2}$$

$$V_{od} = V_{o1} - V_{o2}$$

$$V_{oc} = \frac{V_{o1} + V_{o2}}{2}$$

$$V_{i1} = V_{ic} + \frac{V_{id}}{2}$$

$$V_{i2} = V_{ic} - \frac{V_{id}}{2}$$

$$V_{o1} = V_{oc} + \frac{V_{od}}{2}$$

$$V_{o2} = V_{oc} - \frac{V_{od}}{2}$$

Differential-mode gain:

$$\mathbf{A_{dm}} = \left. \frac{V_{od}}{V_{id}} \right|_{v_{ic}=0}$$

Common-mode gain:

$$\mathbf{A_{cm}} = \left. \frac{V_{oc}}{V_{ic}} \right|_{v_{id}=0}$$

Common-mode-rejection ratio:

$$\mathbf{CMRR} = \left| \frac{\mathbf{A_{dm}}}{\mathbf{A_{cm}}} \right|$$

Differential-Mode

BJT and MOSFET

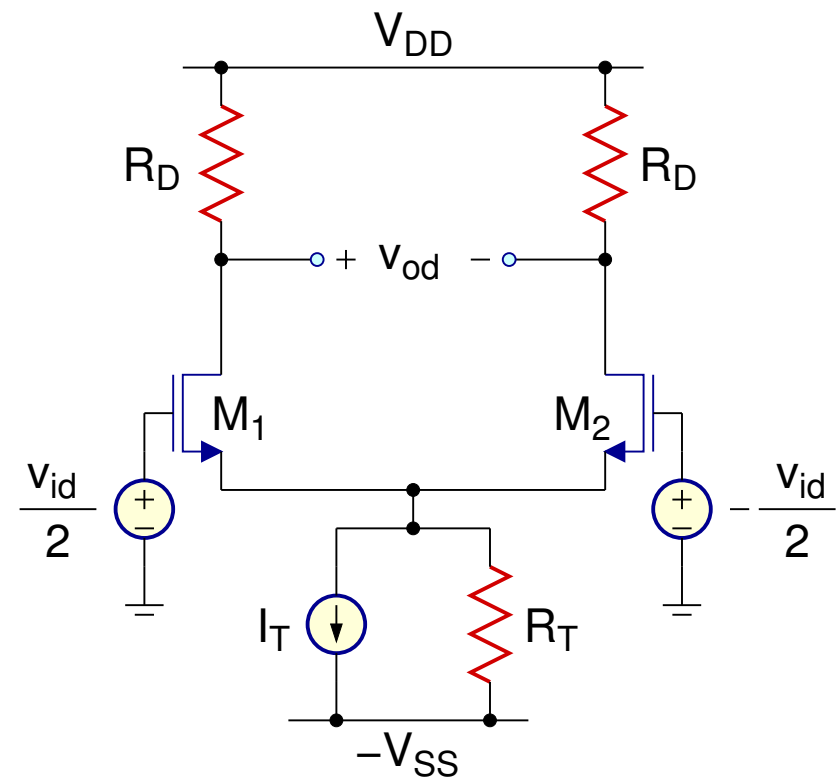
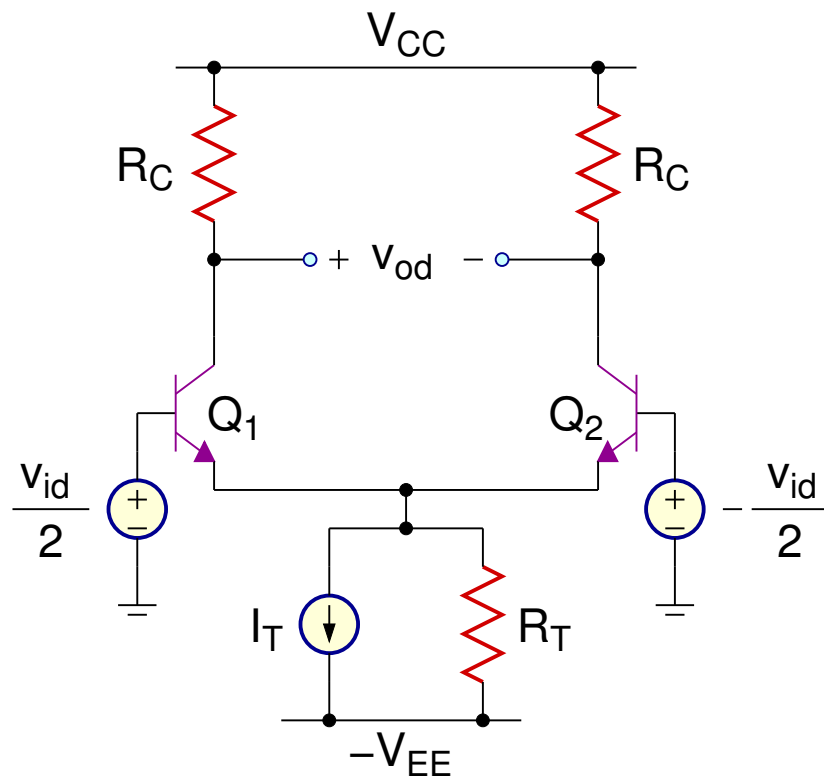

Differential-Mode

Small-signal equivalent

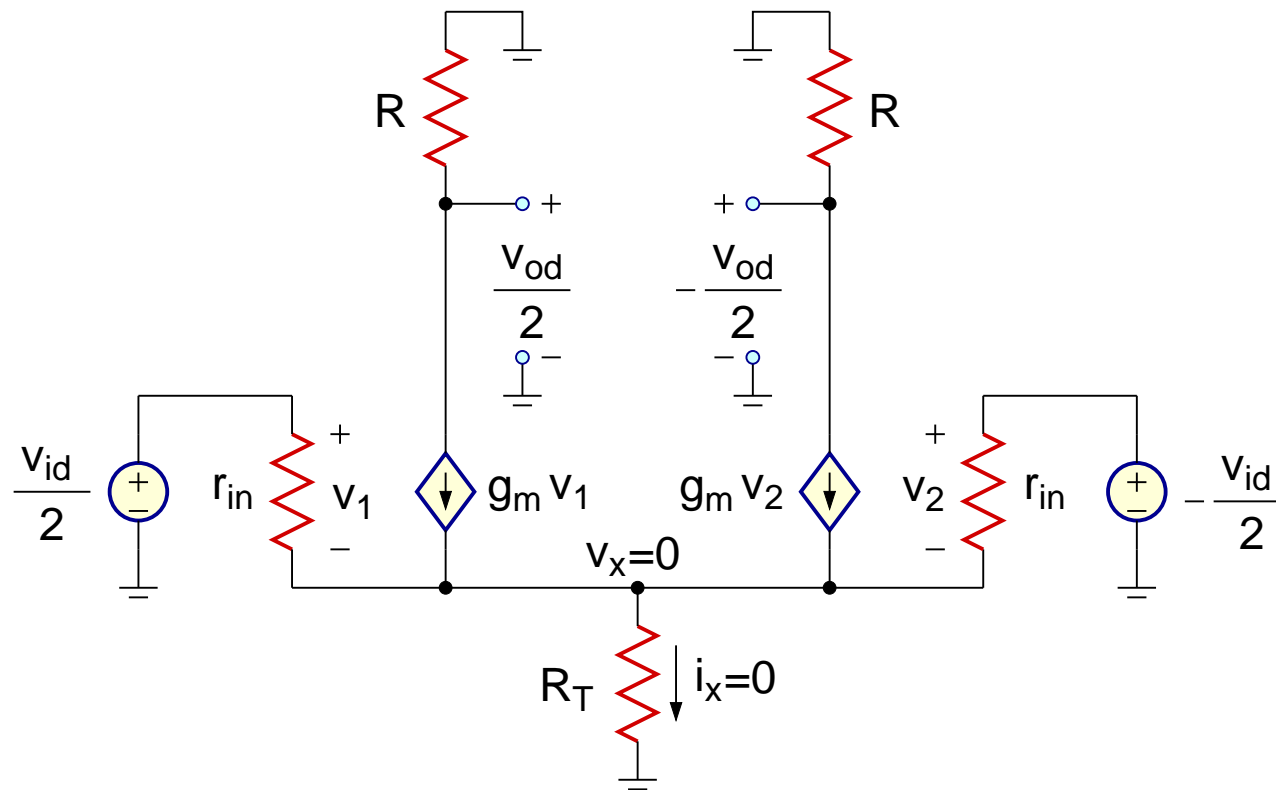

BJT: $r_{in} = r_{\pi}$

$R = R_C$

MOSFET: $r_{in} = \infty$

$R = R_D$

Differential-Mode

Small-signal equivalent

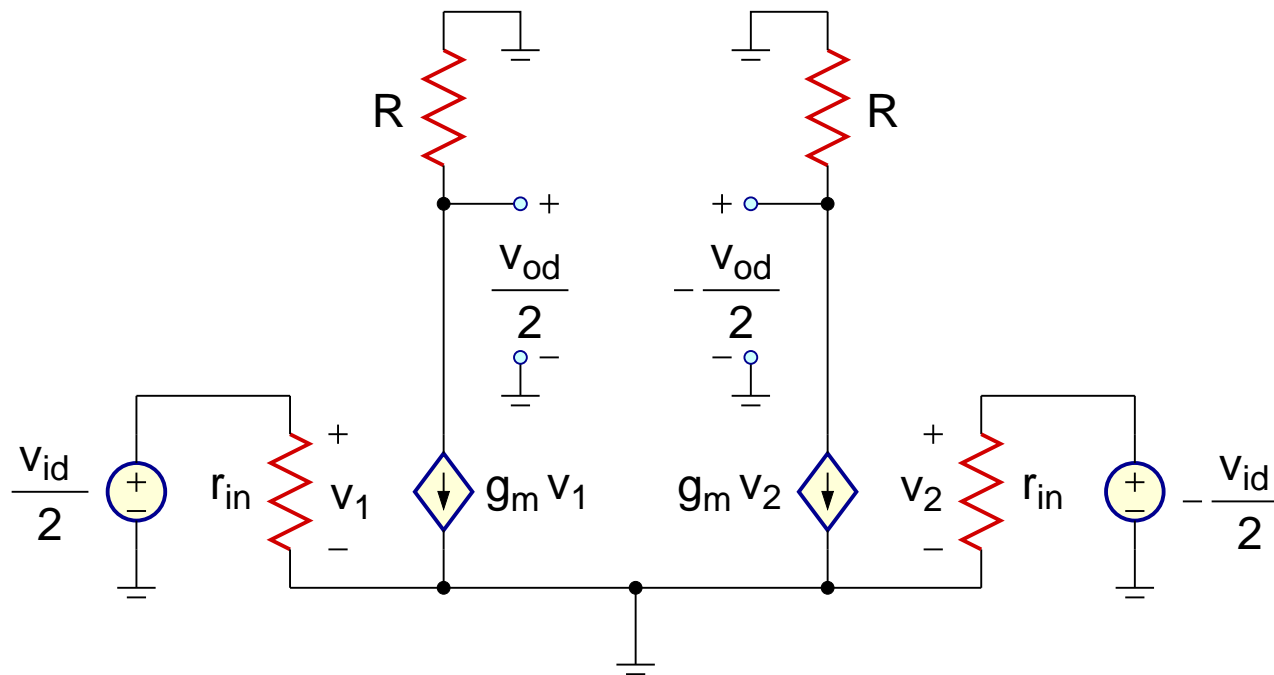

Differential-Mode

Half circuit

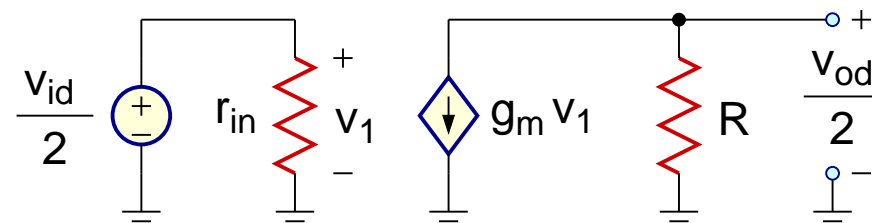

$$\frac{v_{od}}{2} = -g_m R \frac{v_{id}}{2}$$

$$A_{dm} = \left. \frac{v_{od}}{v_{id}} \right|_{v_{ic}=0} = -g_m R$$

Common-Mode

BJT and MOSFET

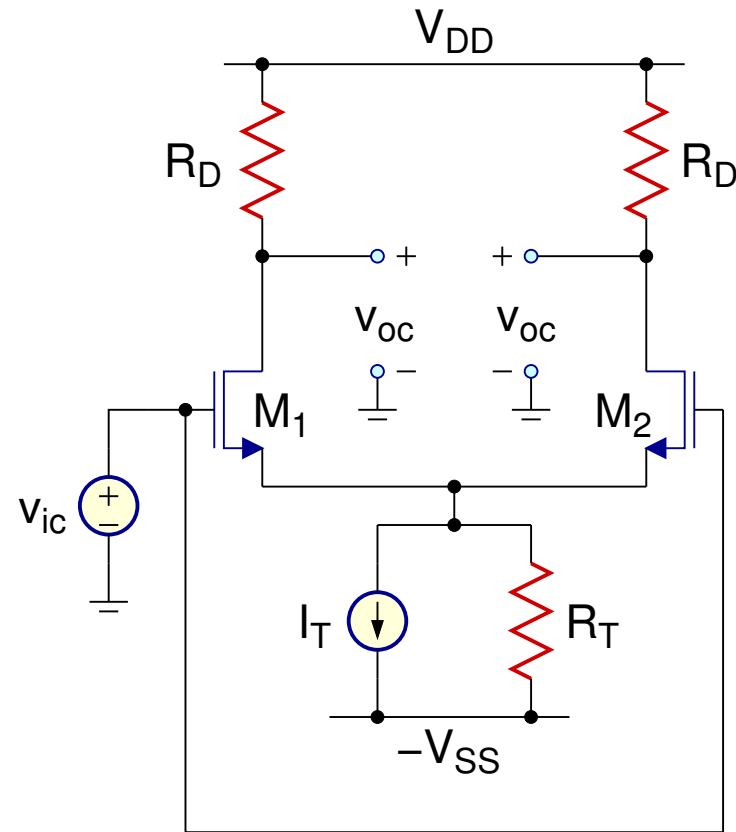
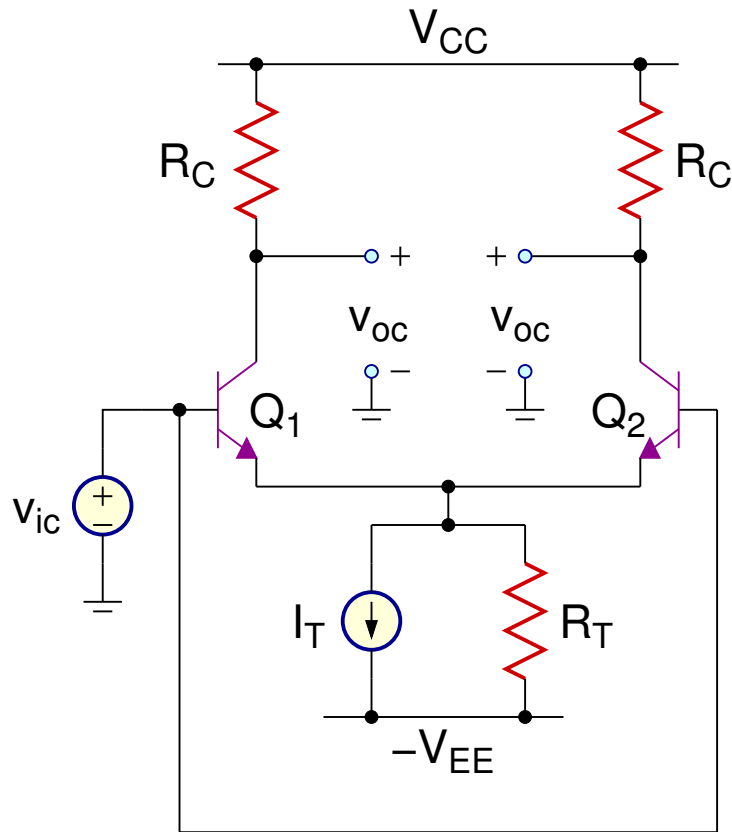

Common-Mode

Small-signal equivalent

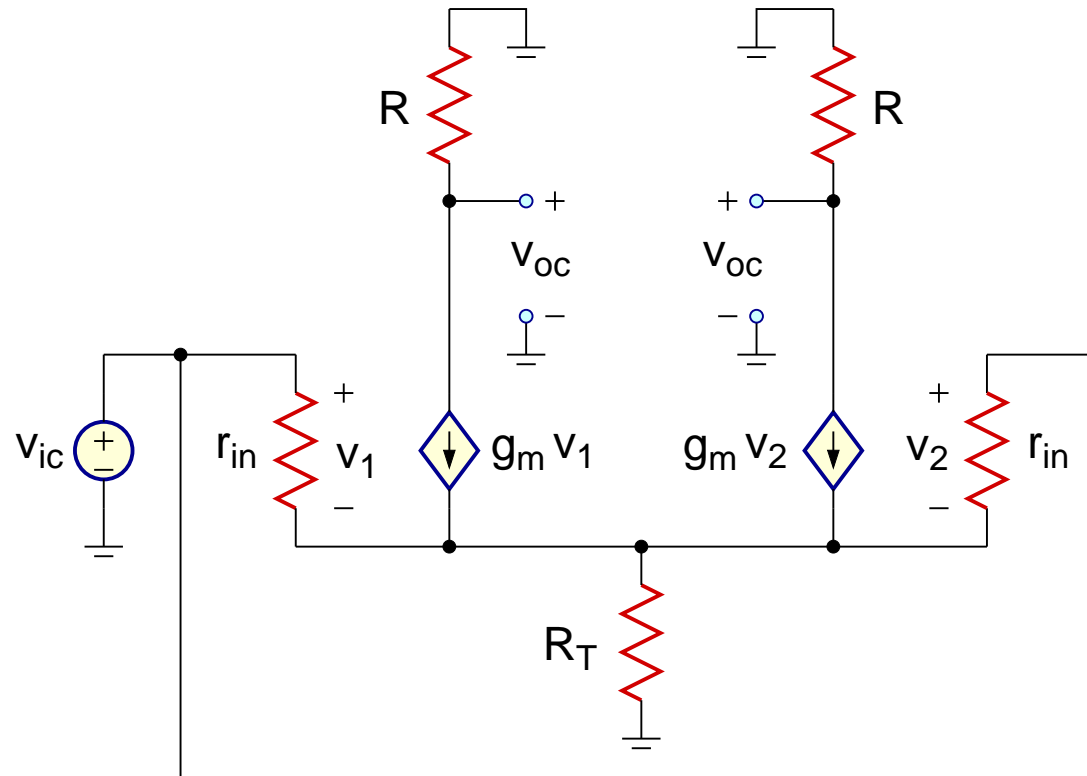

BJT: $r_{in} = r_{\pi}$

MOSFET: $r_{in} = \infty$

$R = R_C$

$R = R_D$

Common-Mode

Small-signal equivalent

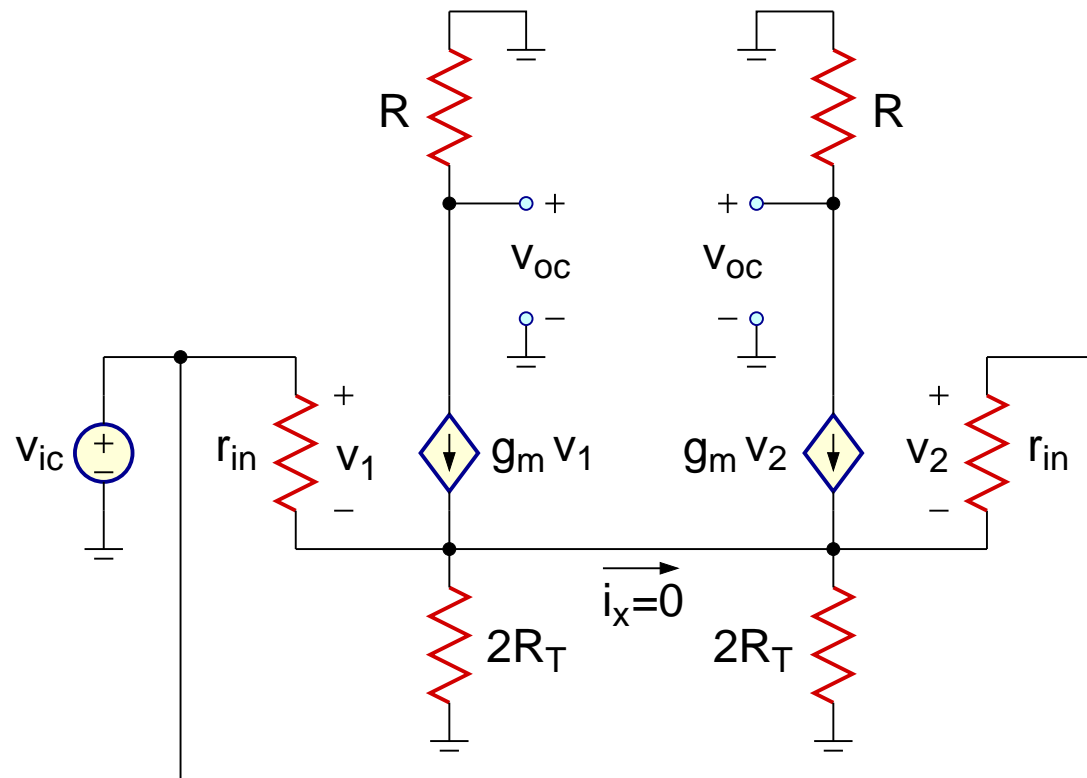

Common-Mode

Small-signal equivalent

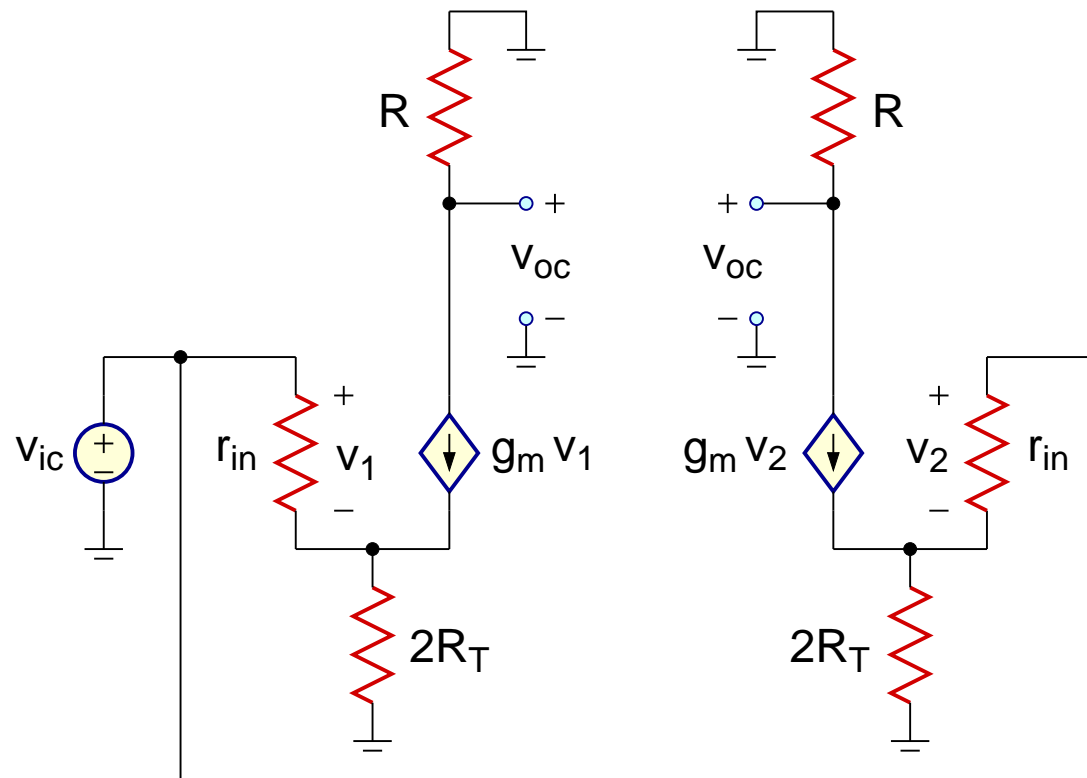

Common-Mode

Half circuit

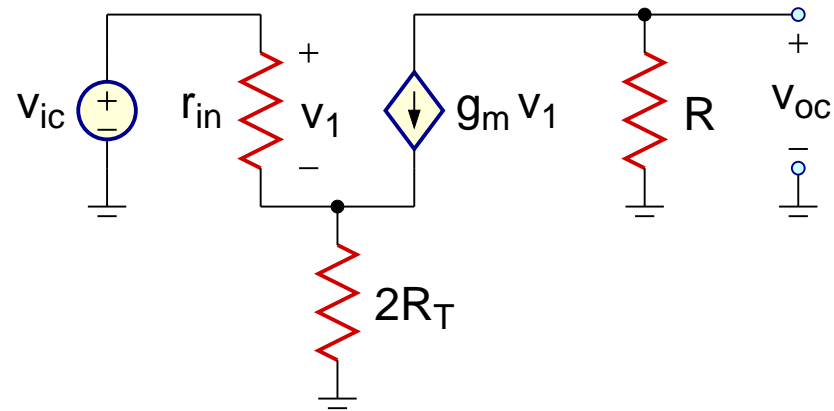

$$V_{oc} = -\frac{R}{\frac{1}{g_m} + 2R_T} V_{ic}$$

$$A_{cm} = \frac{V_{oc}}{V_{ic}} \Big|_{v_{id}=0} = -\frac{R}{\frac{1}{g_m} + 2R_T} = -\frac{g_m R}{1 + 2g_m R_T}$$

CMRR and R_i

$$\text{CMRR} = \left| \frac{A_{dm}}{A_{cm}} \right| = \boxed{1 + 2g_m R_T}$$

$$\frac{v_{id}}{2} = i_{in} r_{in} \Rightarrow R_{id} = \left. \frac{v_{id}}{i_{in}} \right|_{v_{ic}=0} = \boxed{2r_{in}}$$

$$R_{ic} = \left. \frac{v_{ic}}{i_{in}} \right|_{v_{id}=0} = \boxed{r_{in} + (\beta + 1)2R_T}$$

If $R_{ic} \gg R_{id}$, the input resistance can be represented by:

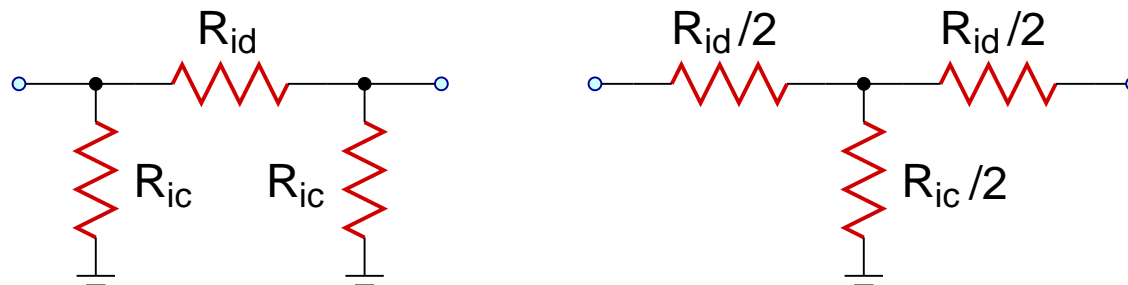

Input Offset Voltage and Current

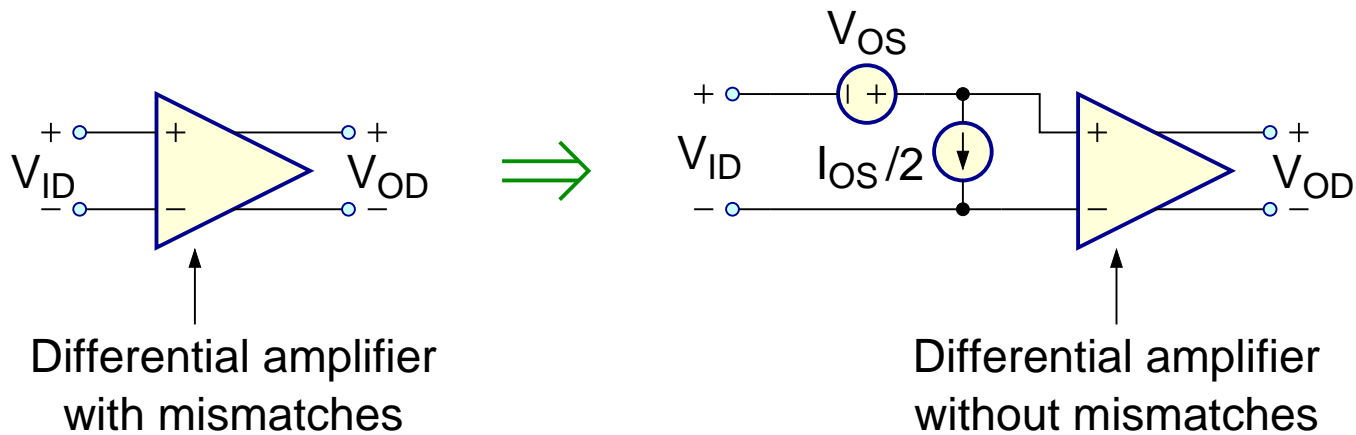

V_{OS} : Input offset voltage

I_{OS} : Input offset current

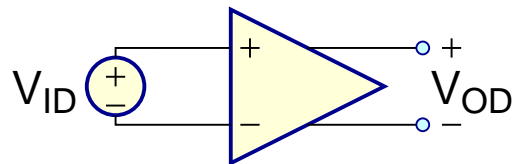

$$V_{OD} = 0 \Rightarrow V_{OS} = V_{ID}$$

Input Offset Voltage

Emitter-coupled pair

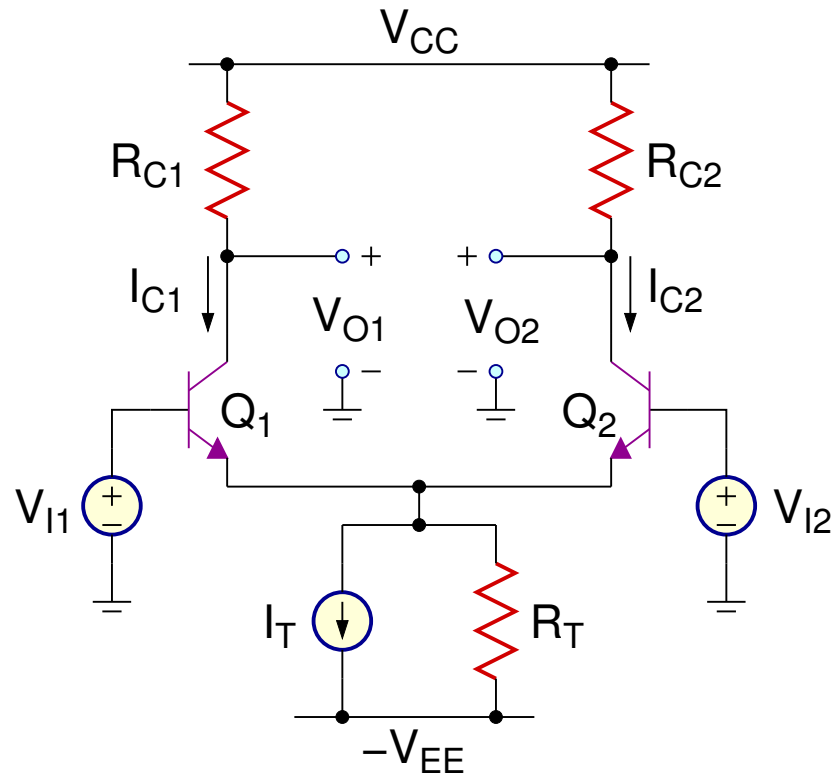

$$\begin{aligned}V_{I1} - V_{I2} &= V_{BE1} - V_{BE2} \\ &= V_T \ln \left(\frac{I_{C1}}{I_{S1}} \right) - V_T \ln \left(\frac{I_{C2}}{I_{S2}} \right) \\ &= V_T \ln \left(\frac{I_{C1} I_{S2}}{I_{C2} I_{S1}} \right)\end{aligned}$$

$$V_{ID} = V_{I1} - V_{I2} = V_T \ln \left(\frac{I_{C1} I_{S2}}{I_{C2} I_{S1}} \right)$$

$$V_{OD} = V_{O1} - V_{O2} = R_{C2} I_{C2} - R_{C1} I_{C1}$$

$$V_{OD} = 0 \Rightarrow V_{OS} = V_{ID}$$

$$\frac{I_{C1}}{I_{C2}} = \frac{R_{C2}}{R_{C1}} \Rightarrow V_{OS} = V_{ID} = V_T \ln \left(\frac{I_{C1} I_{S2}}{I_{C2} I_{S1}} \right) = V_T \ln \left(\frac{R_{C2} I_{S2}}{R_{C1} I_{S1}} \right)$$

$$V_{OS} = V_T \ln \left[\left(\frac{R_{C2}}{R_{C1}} \right) \left(\frac{I_{S2}}{I_{S1}} \right) \right]$$

$$V_{OS} = V_T \ln \left[\left(\frac{R_C - \frac{\Delta R_C}{2}}{R_C + \frac{\Delta R_C}{2}} \right) \left(\frac{I_S - \frac{\Delta I_S}{2}}{I_S + \frac{\Delta I_S}{2}} \right) \right]$$

If $\Delta R_C \ll R_C$ and $\Delta I_S \ll I_S$

$$\begin{aligned} V_{OS} &\approx V_T \ln \left[\left(1 - \frac{\Delta R_C}{R_C} \right) \left(1 - \frac{\Delta I_S}{I_S} \right) \right] \\ &\approx V_T \left[\ln \left(1 - \frac{\Delta R_C}{R_C} \right) + \ln \left(1 - \frac{\Delta I_S}{I_S} \right) \right] \\ &\approx V_T \left(-\frac{\Delta R_C}{R_C} - \frac{\Delta I_S}{I_S} \right) \end{aligned}$$

$$\sigma_{V_{OS}} = V_T \sqrt{(\sigma_{\Delta R_C/R_C})^2 + (\sigma_{\Delta I_S/I_S})^2}$$

Input Offset Current

Emitter-coupled pair

$$I_{OS} = \frac{I_{C1} - I_{C2}}{\beta} \quad \text{when } V_{OD} = 0$$

$$I_{C1} = I_C + \frac{\Delta I_C}{2}, \quad I_{C2} = I_C - \frac{\Delta I_C}{2}$$

$$\beta_1 = \beta + \frac{\Delta\beta}{2}, \quad \beta_2 = \beta - \frac{\Delta\beta}{2}$$

$$I_{OS} = \left(\frac{I_C + \frac{\Delta I_C}{2}}{\beta + \frac{\Delta\beta}{2}} - \frac{I_C - \frac{\Delta I_C}{2}}{\beta - \frac{\Delta\beta}{2}} \right) \approx \frac{I_C}{\beta} \left(\frac{\Delta I_C}{I_C} - \frac{\Delta\beta}{\beta} \right)$$

For V_{OD} to be zero, $I_{C1}R_{C1} = I_{C2}R_{C2}$, therefore,

$$\frac{\Delta I_C}{I_C} = -\frac{\Delta R_C}{R_C} \Rightarrow \boxed{I_{OS} \approx \frac{I_C}{\beta} \left(\frac{\Delta R_C}{R_C} - \frac{\Delta\beta}{\beta} \right)}$$

Input Offset Voltage

Source-coupled pair

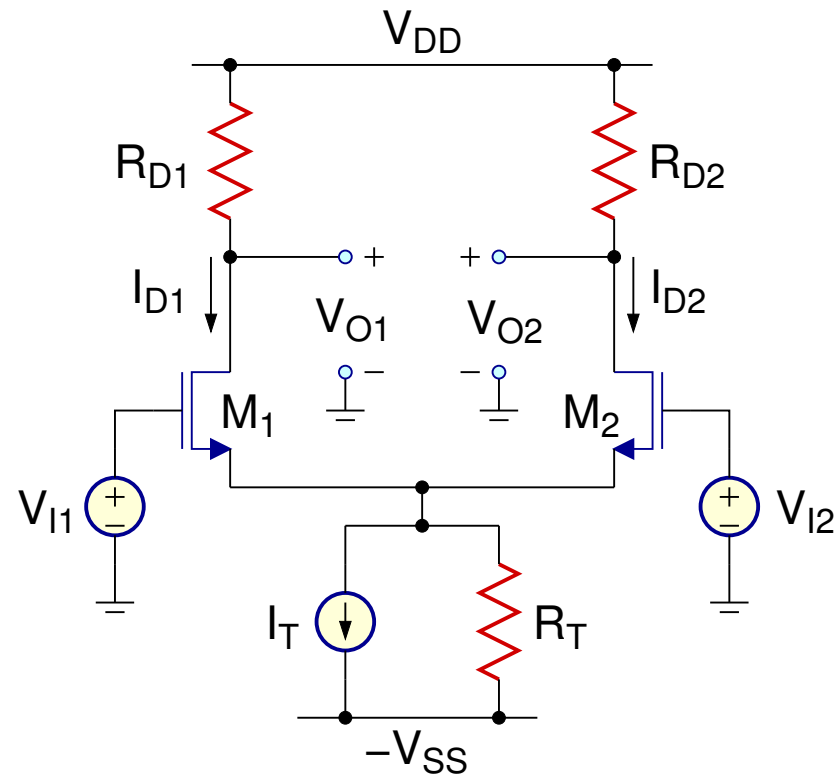

$$V_{ID} = V_{I1} - V_{I2} = V_{GS1} - V_{GS2}$$

$$= V_{t1} + \sqrt{\frac{2I_{D1}}{k'(W/L)_1}} - V_{t2} - \sqrt{\frac{2I_{D2}}{k'(W/L)_2}}$$

$$V_{OD} = V_{O1} - V_{O2} = R_{D2}I_{D2} - R_{D1}I_{D1}$$

$$V_{OD} = 0 \Rightarrow V_{OS} = V_{ID}$$

$$V_{OS} = V_{t1} - V_{t2} + \sqrt{\frac{2I_{D1}}{k'(W/L)_1}} - \sqrt{\frac{2I_{D2}}{k'(W/L)_2}}$$

where

$$\frac{I_{D1}}{I_{D2}} = \frac{R_{D2}}{R_{D1}}$$

$$V_{OS} \approx \Delta V_t + \frac{(V_{GS} - V_t)}{2} \left(-\frac{\Delta R_D}{R_D} - \frac{\Delta(W/L)}{(W/L)} \right)$$