

*Analog and Mixed-Signal Center*

# Receiver Architectures: Fundamentals and Properties

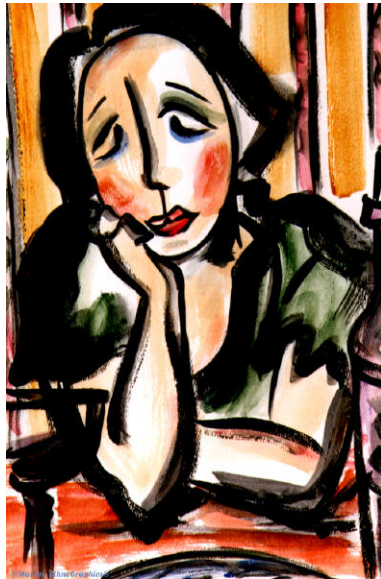

How can we relax or solve this image rejection problem ?

A possible solution is the use of more than one IF stage. This can relax the specs of the filters and other building blocks. How many IF stages are required ?



This depends on the design specs, a rule of thumb is to keep the ratio between the operating frequency before and after a downconversion should be lower than 10. Say for a signal at 900 MHz can be first downconverted to an IF of 250 MHz, then filter out unwanted signal and second downconverted to 50 MHz and in a third downconversion the IF is 10 MHz.

How complex will be the filtering, power consumption and cost?

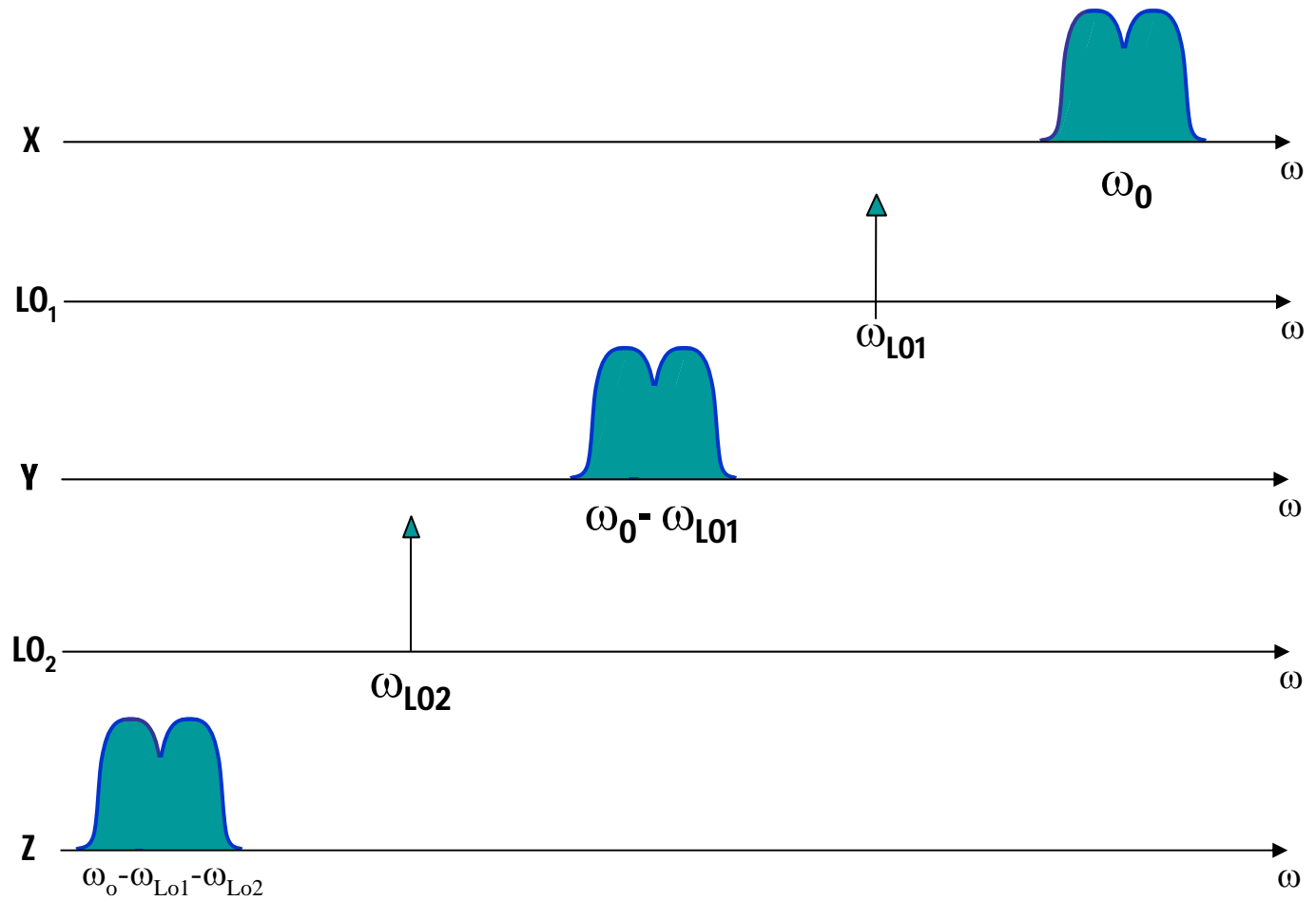
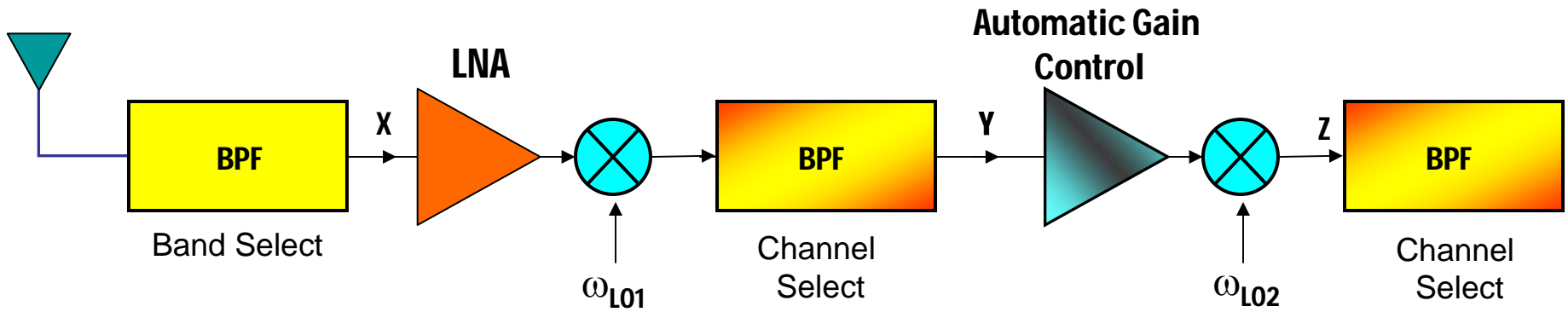

Double Superheterodyne Architecture

# Multi-Stage IF Receivers

- From stage to stage the desired signal is further and further downconverted until the desired final IF is obtained.
- The ratio between the operating frequency before and after downconversion is usually kept lower than 10, say 4. For instance a 1800 MHz signal is first downconverted to a first IF of 450 MHz, then consecutively to 90 MHz and finally to 18 MHz.
- Note that each downconversion stage has the same mirror frequency trouble than the single-stage IF receiver.
- Significant filtering between stages is required. This filtering is done with off chip filters to further complicate the sensitivity to parasitic components, also the power consumption will be high.

## How are the $\omega_{LO}$ and $\omega_{IF}$ selected?

- Key consideration is the so-called image frequency.
- Ideally  $\omega_{IF}$  should be high enough such that  $\omega_{IMA}$  never falls in band.
- There are two possible choices for  $\omega_{LO}$

$$\omega_{LO} = \omega_{RF} + \omega_{IF} \quad \text{High side injection}$$

or

$$\omega_{LO} = \omega_{RF} - \omega_{IF} \quad \text{Not a good choice}$$

- Regarding  $\omega_{IF}$ , one has to consider the VCO tuning range.

Assume the AM case {530 to 1,610} KHz = BW

$$\omega_{IF} = \frac{BW}{2}$$
$$\omega_{IF} = \frac{(1,610 - 530)}{2} \text{ KHz} = 540 \text{ KHz} \neq 455 \text{ KHz}$$

Case 1.  $\{75 \text{ to } 1,155\} \text{KHz}$

$$75 \text{KHz} = (530 - 455) \text{KHz}$$

$$1,155 \text{KHz} = (1,610 - 455) \text{KHz}$$

$\omega_{LO}$  frequency span 15.4

Case 2.  $\{985 \text{ to } 2,065\} \text{KHz}$  High side injection

$$985 \text{KHz} = 530 \text{KHz} + 455 \text{KHz}$$

$$2,065 \text{KHz} = (1,610 + 455) \text{KHz}$$

$\omega_{LO}$  frequency span 2.01

For VCO tuning reason, Case 2 is more attractive.

-Explore the case of FM VCO range.

Aside, there is a trade-off in IF selection; low IF improves the selectivity due to a Lower Q requirement of the SAW filter, while a high IF enhances the sensitivity due to higher attenuation that can be offered by the image-rejection filter.

# IMAGE FREQUENCY PROBLEM

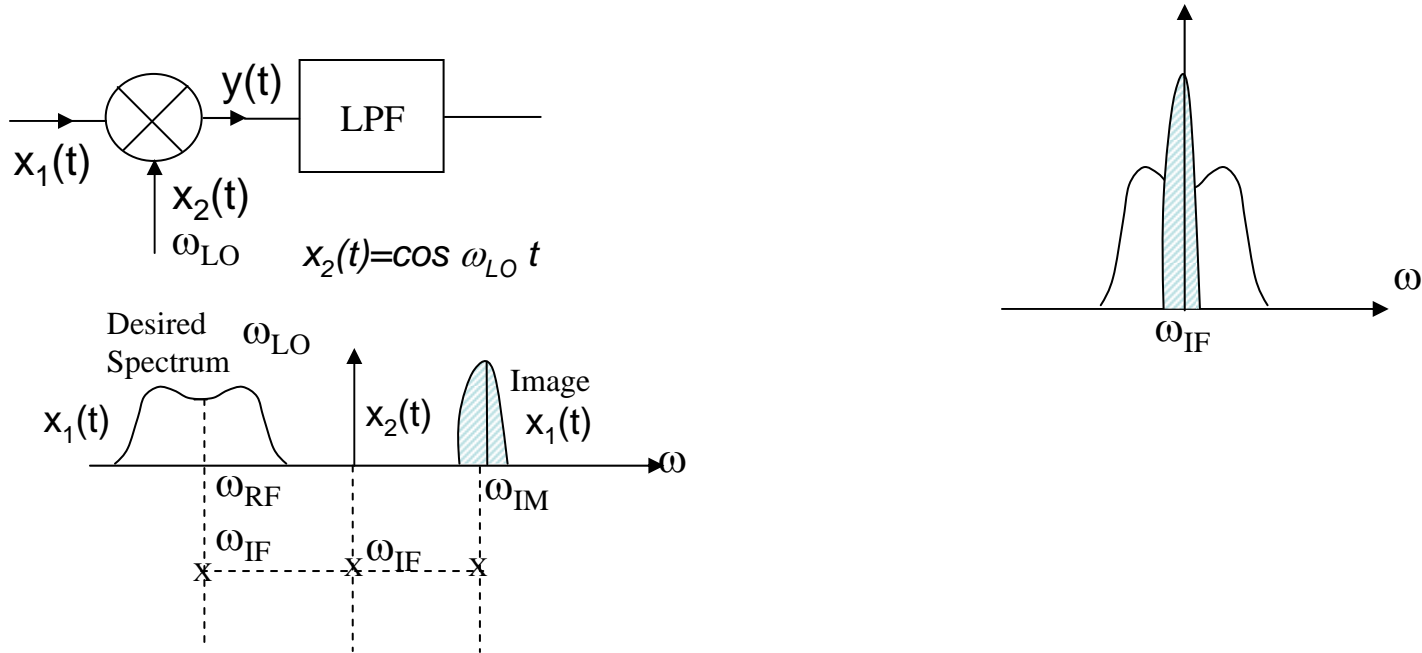

How to tackle this image frequency problem?

- Add a filter before and after

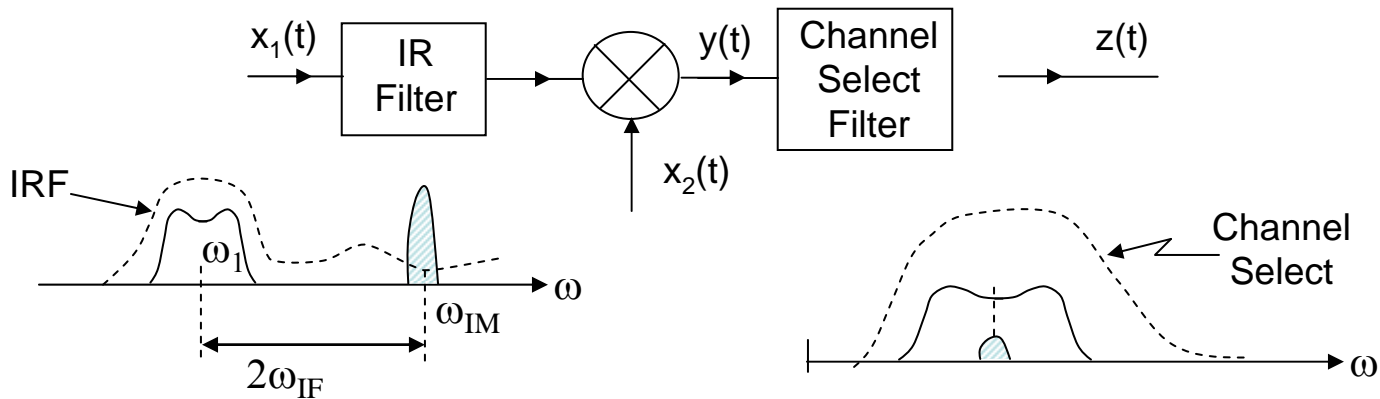

The conventional receiver (RX) Architectures are:

- 1. Superheterodyne**
- 2. Image Reject RX: Hartley and Weaver**
- 3. Zero-Intermediate Frequency (IF)**
- 4. Low –Intermediate Frequency (IF)**

These are the most used architectures in CMOS Receivers reported in the literature. The selection of the architecture is partially dependent on the standards. However some standard such as the GSM/DCS/PCS/EDGE have been designed using options 1, 3 and 4. Others such as Bluetooth have been dominated by low-IF Architecture. In other cases for multi-standards for instance the 802.11a/b/g the Zero-IF has been the dominant architecture for their implementations.

Next we discuss these architectures and their pros and cons.



# Super Heterodyne Receiver with Quadrature Down-conversion

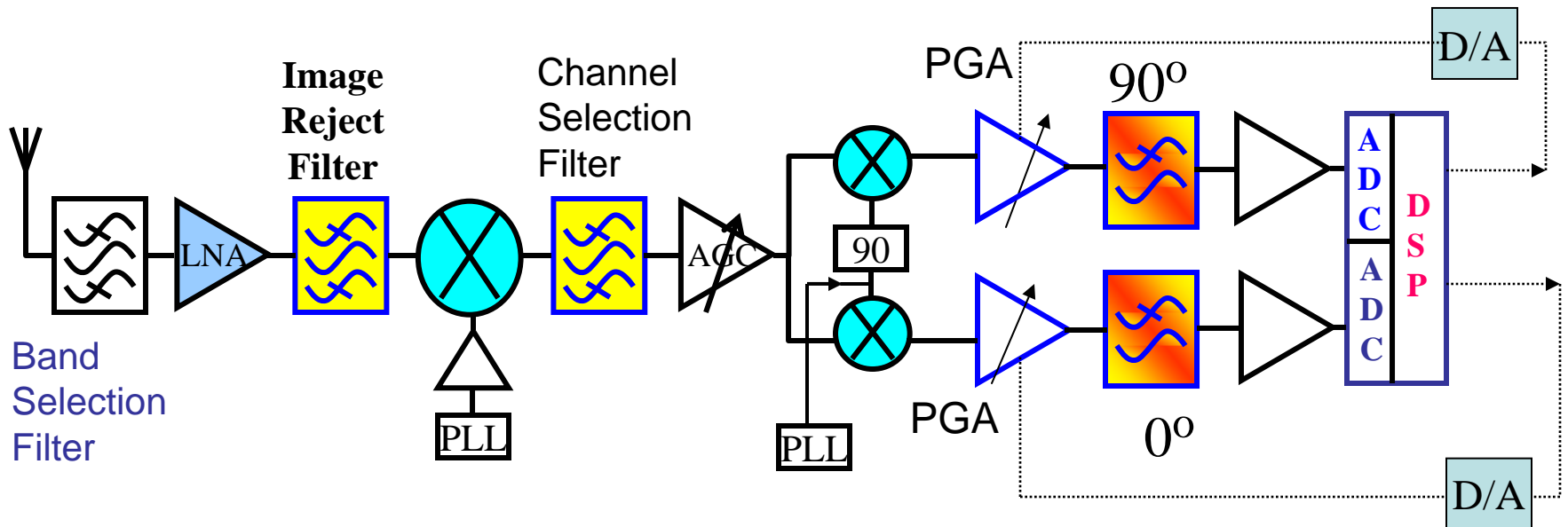

- **Good performance in terms of image and spurious suppression.**
- **A complex mixer is required.**
- ***In the DSP a complex non-linear algorithm control the DC-level dynamically.***
- **Low integration due to the use of SAW filters.**
- **Limited multi-standard ability.**

**Due to the difficulty to design broadband I/Q phase shifters an alternative solution (*Weaver*) solution is next discussed.**

# HARTLEY Image Rejection RX

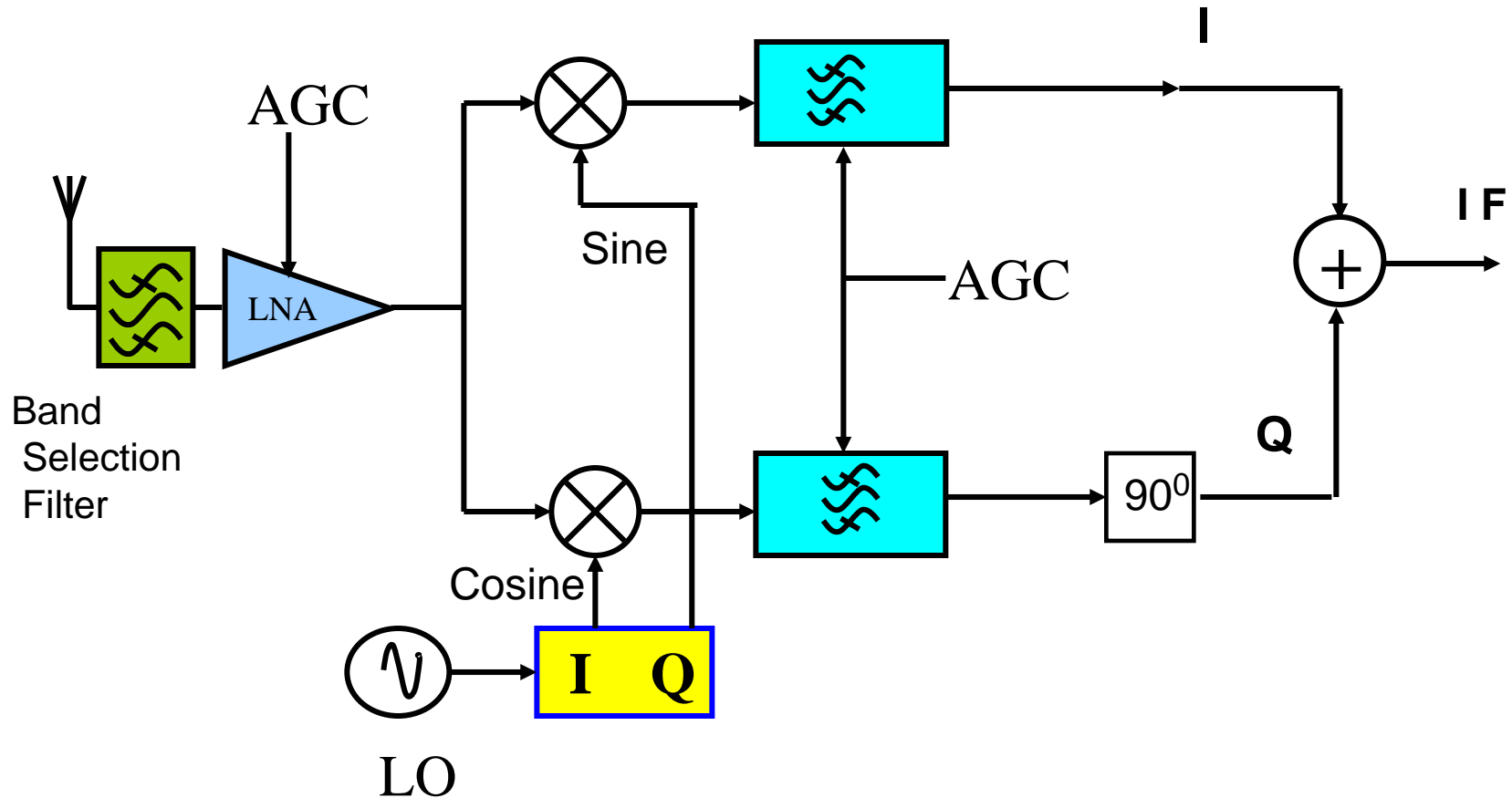

- Ideally the image is rejected, in practice the static gain/phase mismatches are 0.2 to 0.6 db/1° to 5°, corresponding to an image rejection of roughly 30 to 40dB.

# Image Rejection Mixer Analysis

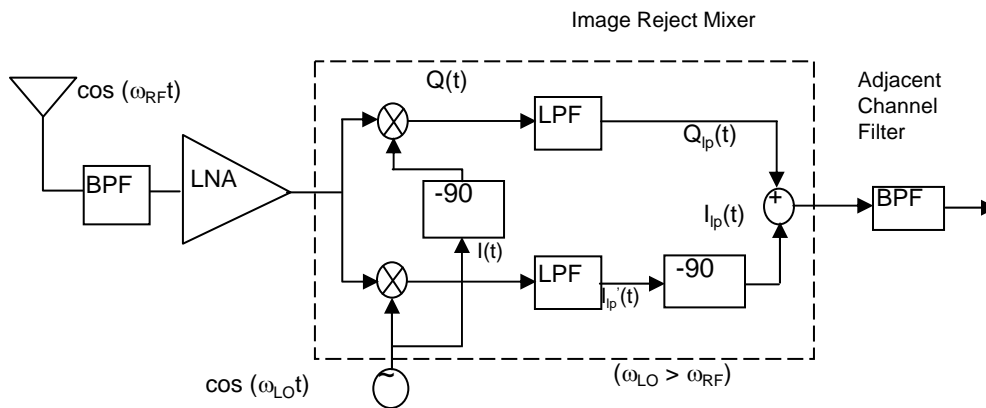

$$I(t) = \cos(\omega_{LO}t) \cdot \cos(\omega_{RF}t)$$

$$= 0.5 \{ \cos[(\omega_{LO} - \omega_{RF})t] + \cos[(\omega_{LO} + \omega_{RF})t] \}$$

$$Q(t) = \sin(\omega_{LO}t) \cdot \cos(\omega_{RF}t)$$

$$= 0.5 \{ \sin[(\omega_{LO} - \omega_{RF})t] + \sin[(\omega_{LO} + \omega_{RF})t] \}$$

$$I_{lp}(t) = 0.5 \cos[(\omega_{LO} - \omega_{RF})t] = 0.5 \cos(\omega_{IF}t)$$

$$Q_{lp}(t) = 0.5 \sin[(\omega_{LO} - \omega_{RF})t] = 0.5 \sin(\omega_{IF}t)$$

$$I_{lp}(t) = 0.5 \cos(\omega_{IF} - 90^\circ) = 0.5 \sin(\omega_{IF}t)$$

$$\Rightarrow v_o(t) = I_{lp}(t) + Q_{lp}(t) = \sin(\omega_{IF}t).$$

The **image input** signal, for *high-side injection* of the LO, is  $v_{i,im}(t) = \cos[(\omega_{LO} + \omega_{IF})t]$ .

$$I(t) = \cos[(\omega_{LO} + \omega_{IF})t] \cdot \cos(\omega_{LO}t) = 0.5 \{ \cos(\omega_{IF}t) + \cos[(2\omega_{LO} + \omega_{IF})t] \}$$

$$I_{lp}(t) = 0.5 \cos(\omega_{IF}t)$$

$$I_{lp}(t) = 0.5 \sin(\omega_{IF}t)$$

$$Q(t) = \sin(\omega_{LO}t) \cdot \cos[(\omega_{LO} + \omega_{IF})t] = 0.5 \sin(-\omega_{IF}t) + 0.5 \sin[(2\omega_{LO} + \omega_{IF})t]$$

$$Q_{lp}(t) = -0.5 \sin(\omega_{IF}t)$$

$$\Rightarrow v_{o,Im}(t) = I_{lp}(t) + Q_{lp}(t) = 0; \text{ Image response can be completely suppressed.}$$

# The Barber-Weaver Receiver

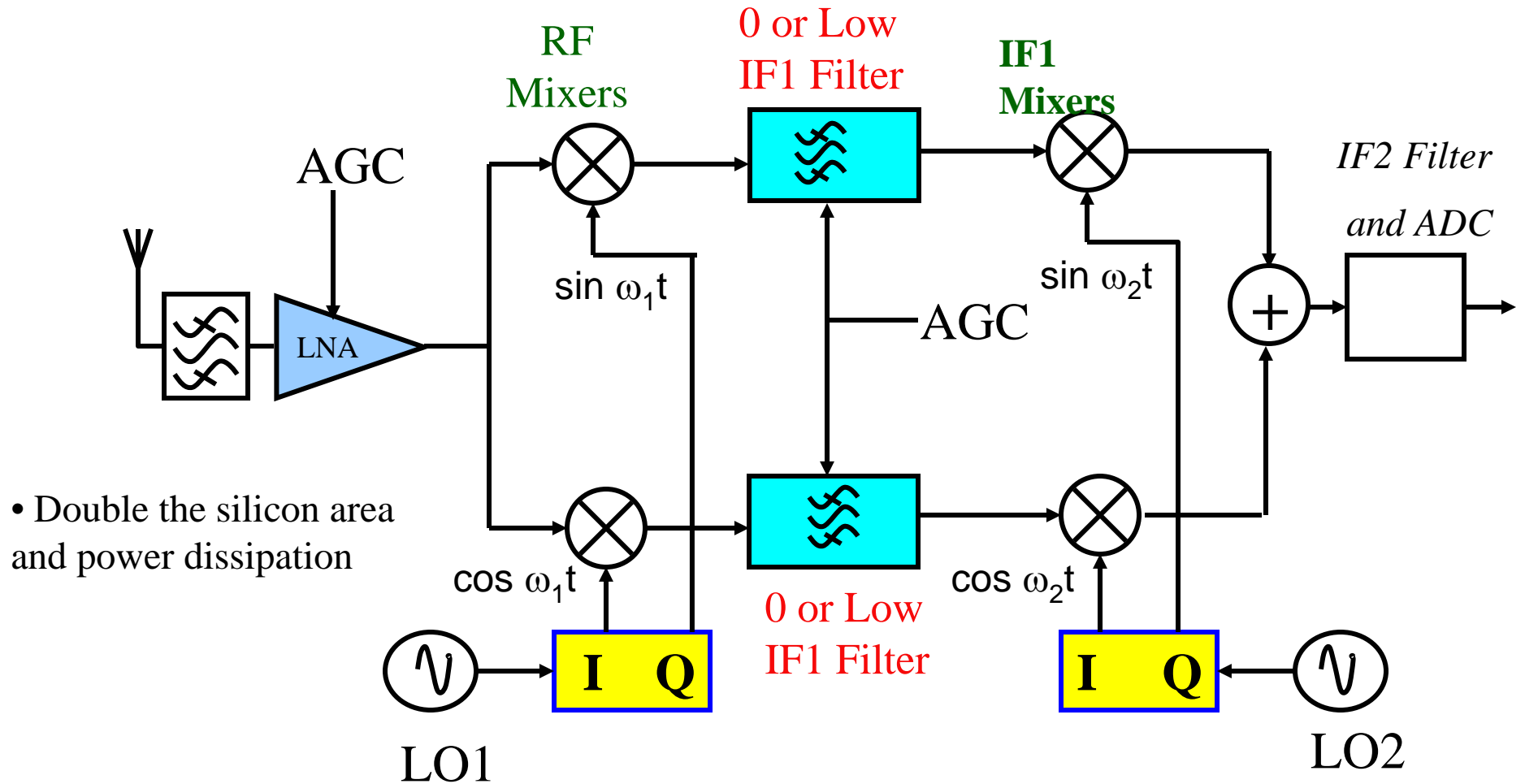

• Difficult Matching of I & Q Paths

; - No phase shifter ( $90^\circ$ ) needed

• Operates with low IF1 and IF2

; - overhead in area for LO2, mixers.

# Signals in the Weaver Architecture

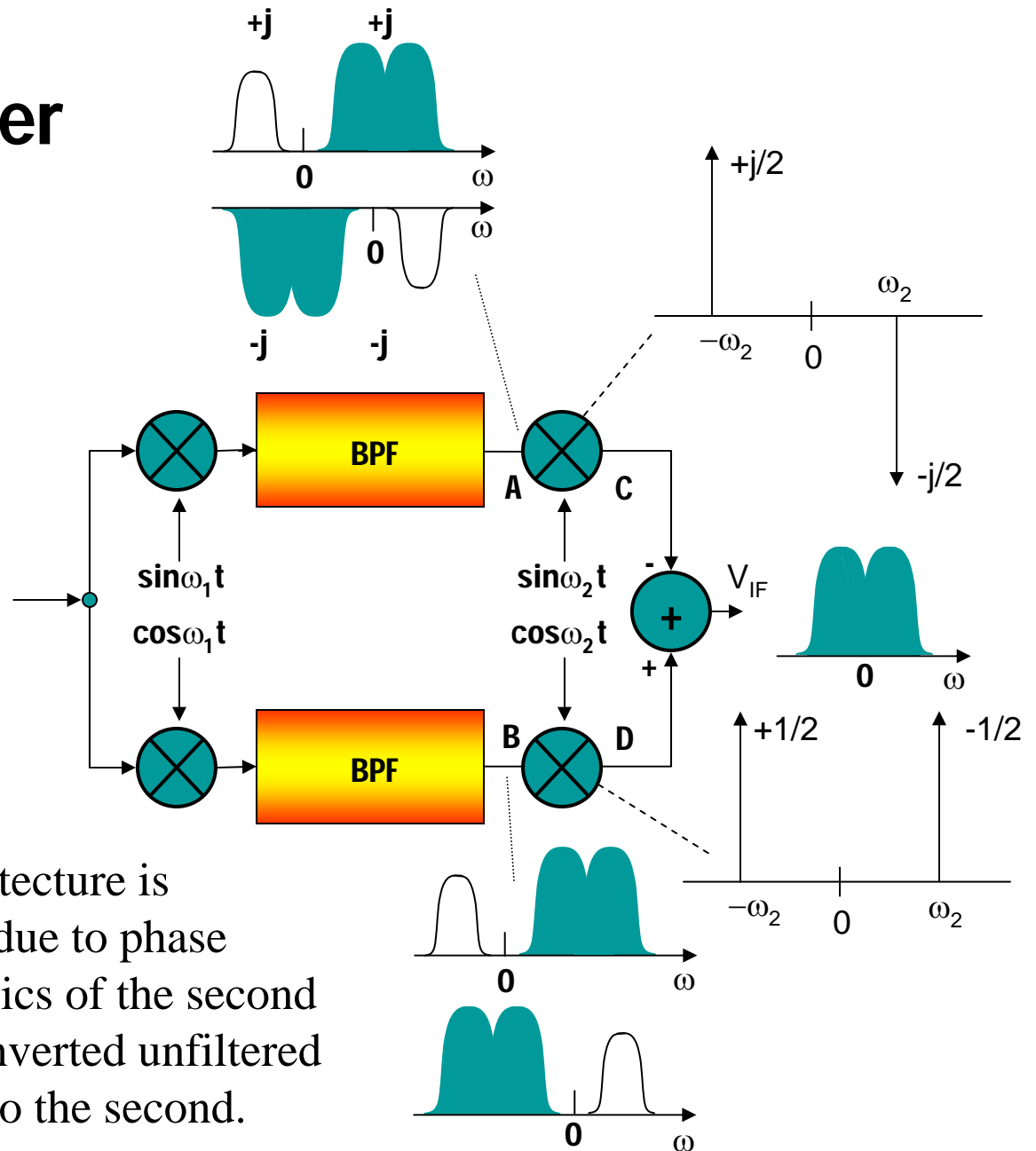
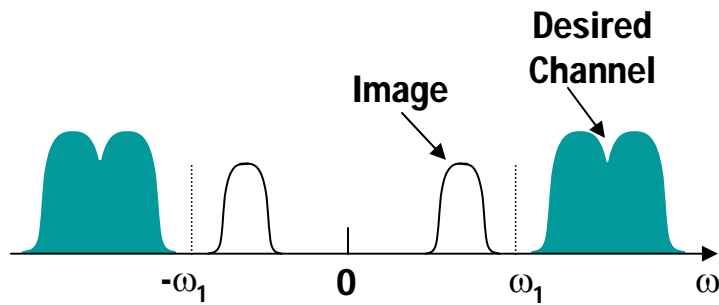

Main drawback of this architecture is incomplete image rejection due to phase and gain mismatch. Harmonics of the second LO frequency may downconverted unfiltered interferers from the first IF to the second.

# Problem of Secondary Image

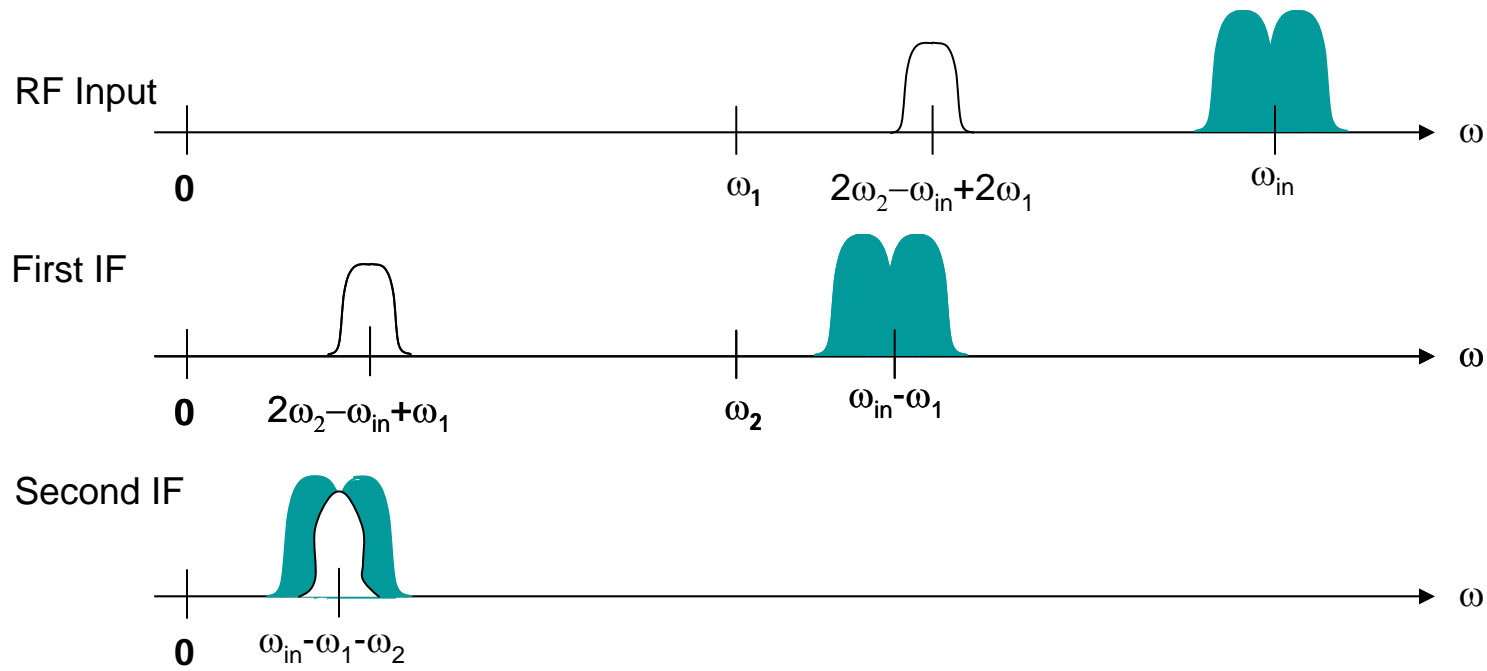
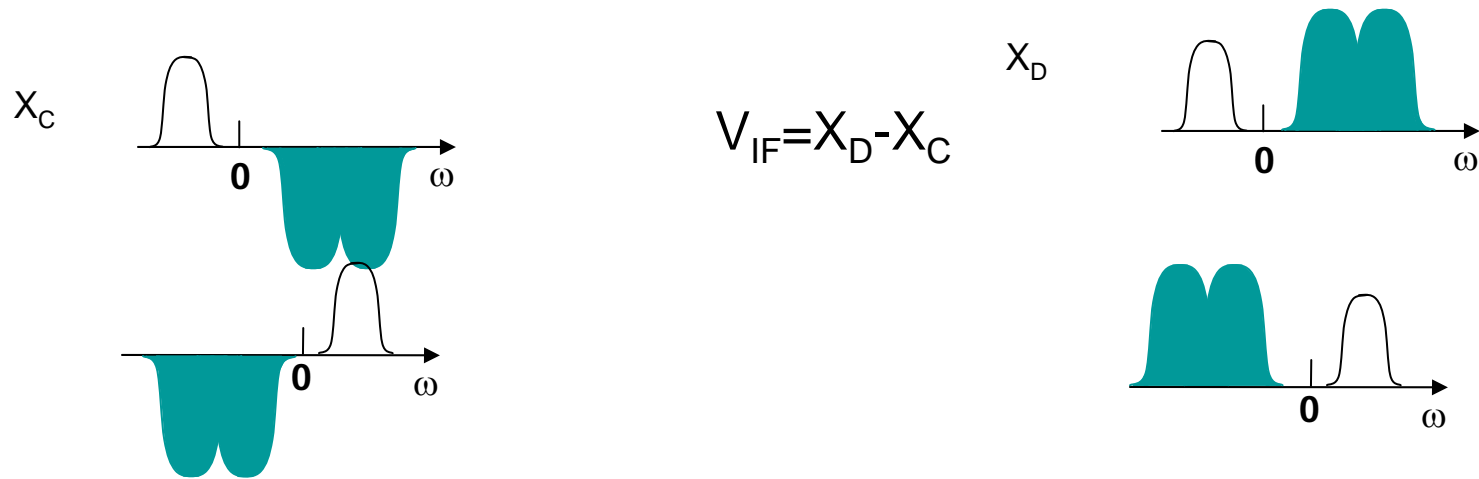

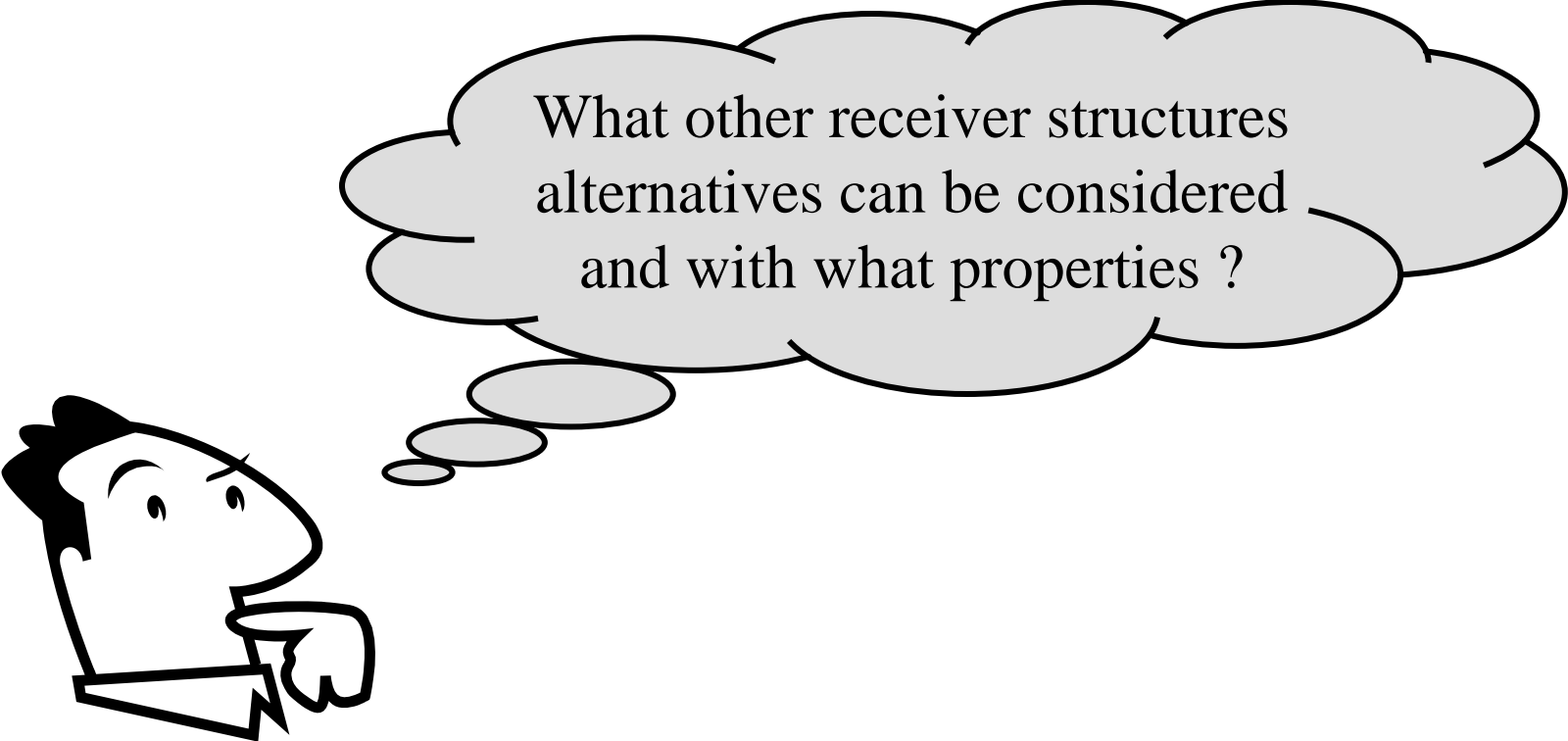

What other receiver structures  
alternatives can be considered  
and with what properties ?



Can we make the IF very low, say to DC ?  
How and at what price ?

**Direct Conversion (IF=0)**

# Direct Conversion or Zero-IF front end Receiver

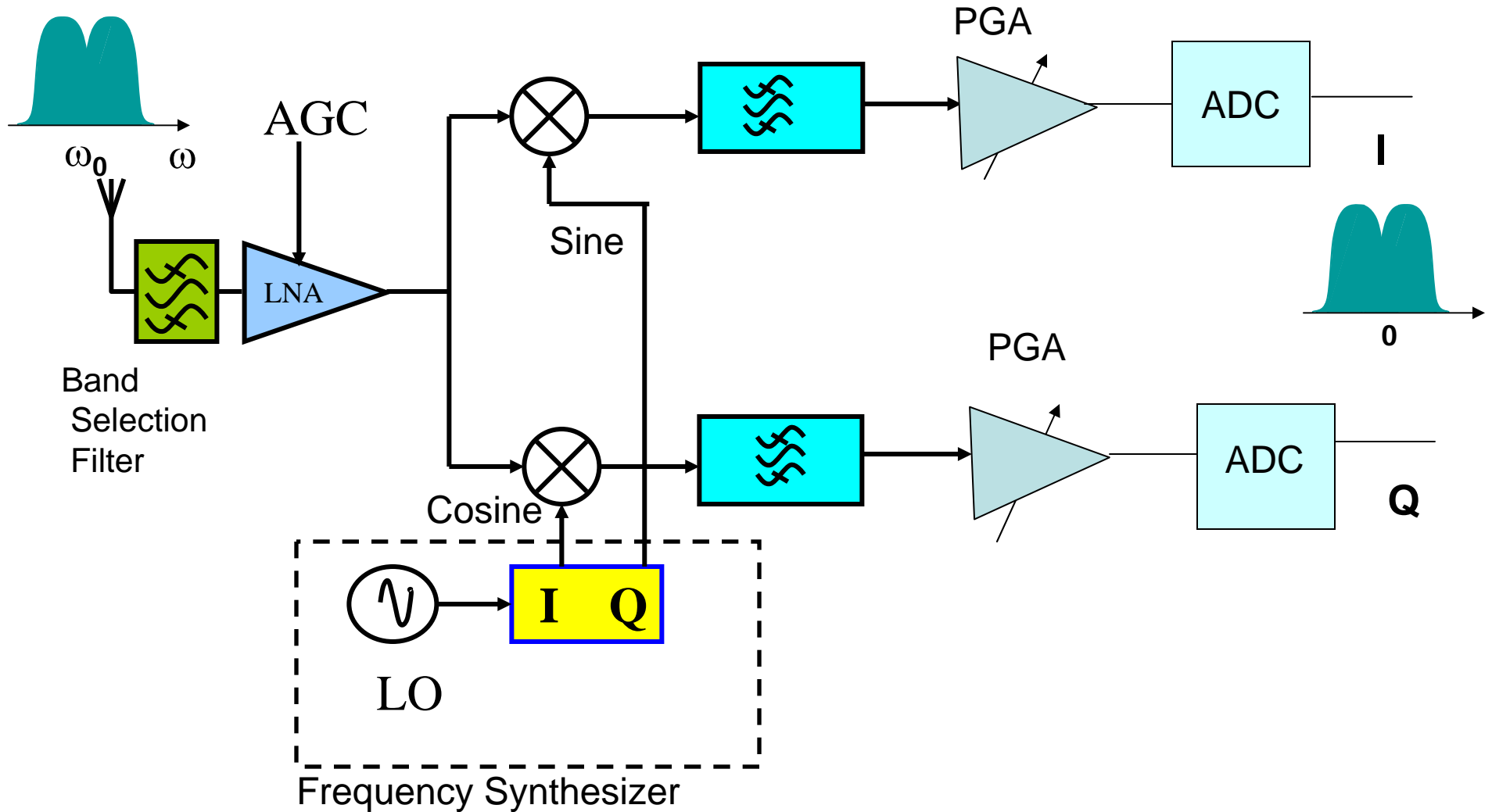



# *Direct Conversion or Zero-IF front end Receiver*



- The LPF can be integrated. No image signal exists
- The RF spectrum is translated to the baseband in the first downconversion.
- The LO is equal to the input carrier frequency.



• This architecture operates only with double-sideband AM signals because it overlaps negative and positive parts of the input spectrum. <sup>ω</sup>



• For frequency and phase-modulated signals, the downconversion needs quadrature outputs. *Two sides of FSK (or QPSK) carry different information.*

# Direct Conversion Front End Receiver With Quadrature Down-Conversion for FSK (digital) Demodulation

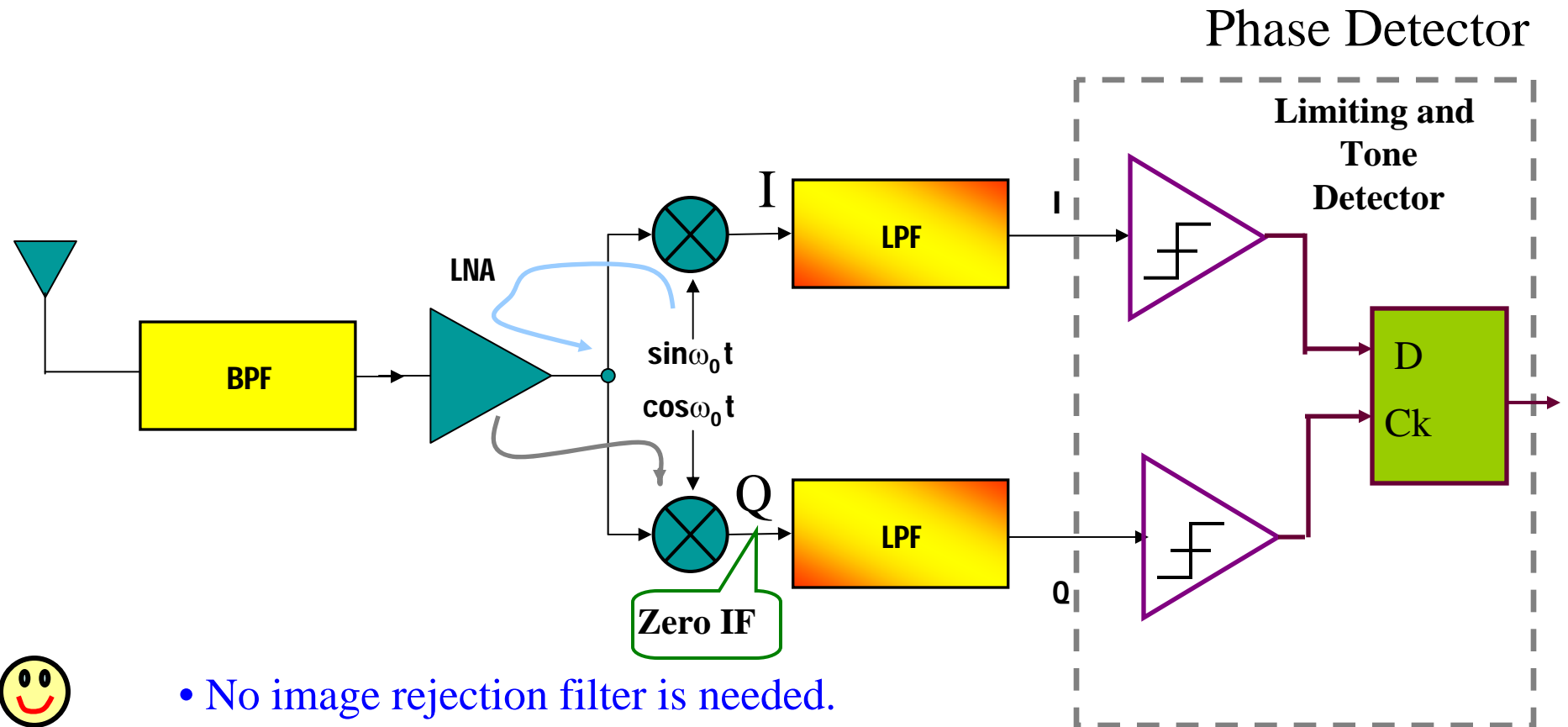

- No image rejection filter is needed.



- Offset voltages can degrade the S/N and saturate the following stages. Isolation between ports is not ideal.
- I/Q mismatch degrades the downconversion constellation

## FSK Direct Conversion Receiver.-

The frequency shift keyed signals appear with opposed relative phase at the phase detector, giving a binary mark or space output according to whether the input signal is lower or higher than the local oscillator frequency. Let assume these inputs (mark and space) signals are:

$$S_M = \cos(\omega + \omega_D)t$$

$$S_S = \cos(\omega - \omega_D)t$$

The quadrature oscillator signals to the mixers are:

$$LO_I = \cos \omega t$$

$$LO_Q = \sin \omega t$$

The mixer outputs when a **mark** is sent are:

$$I_M = S_M \cdot LO_I = \cos(\omega + \omega_D)t \cdot \cos \omega t$$

$$I_M = 0.5[\cos(\omega + \omega_D) + \cos \omega_D t]$$

$$Q_M = S_M \cdot LO_Q = \cos(\omega + \omega_D)t \cdot \sin \omega t$$

$$Q_M = 0.5[\sin(2\omega + \omega_D)t - \sin \omega_D t]$$

Similarly when a **space** is sent:

$$I_S = 0.5[\cos \omega_D t + \cos(2\omega + \omega_D)t]$$

$$Q_S = 0.5[\sin(2\omega - \omega_D)t + \sin \omega_D t]$$

The double frequency components of I and Q are removed in the LPF of each channel, yielding:

$$I_M = +0.5 \cos \omega_D t$$

$$Q_M = -0.5 \sin \omega_D t$$

$$I_S = +0.5 \cos \omega_D t$$

$$Q_S = +0.5 \sin \omega_D t$$

# Direct-Conversion Receiver (continues)

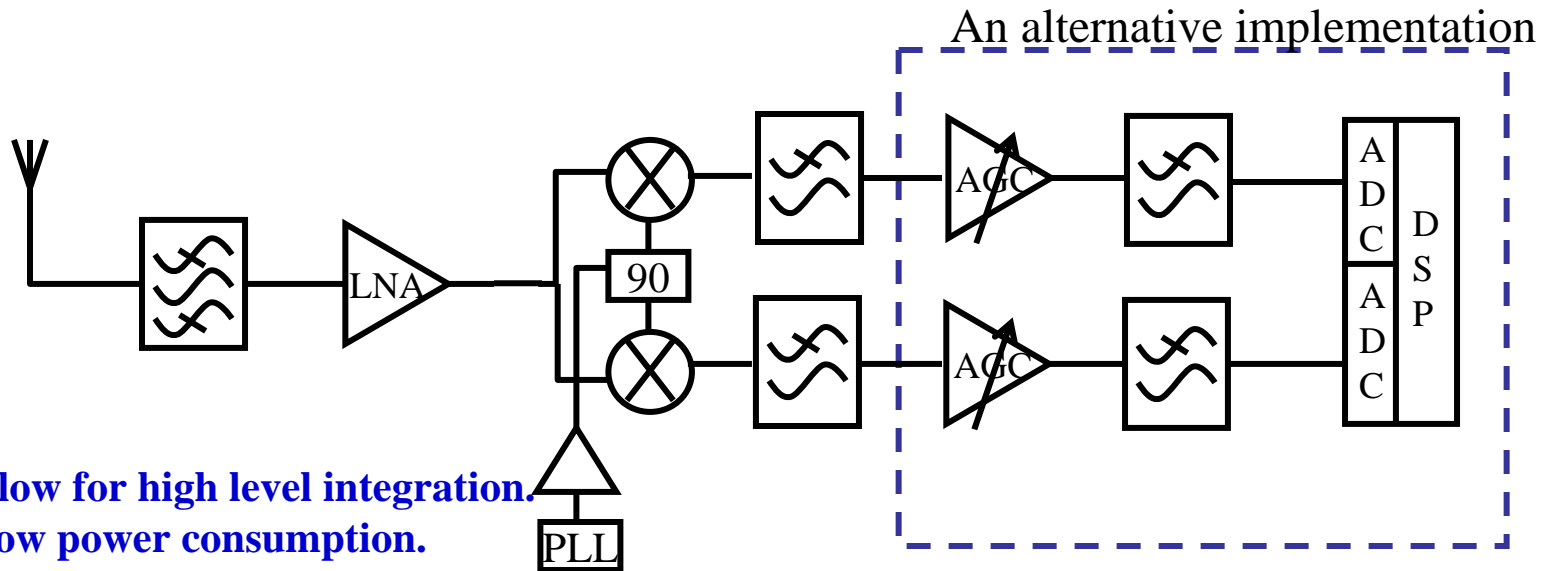

- ✓ Allow for high level integration.
- ✓ Low power consumption.
- ✓ Eliminate passive IF filters
- ✓ Good for SSB digital modulation
- ✓ Good Multi-standard ability.
- DC offset problem.
- Increased ADC dynamic range.  
Because of limited filtering
- Need of a high-Q VCO.

- Moves design efforts to baseband.
- Unprotected LO leakage into antenna.
- I/Q match required over high gain range

# Low IF Receiver Architecture

- All advantages of direct conversion.
- More difficult image rejection.
- DC spur (offset) outside the signal bandwidth.
- Digital processing includes adjacent channel image rejection.
- All weakness of direct conversion without the DC offset problem.
- In Band image rejection.

# 0.35 $\mu\text{m}$ CMOS Bluetooth Low-IF Receiver IC: *An example of a Low-IF topology*

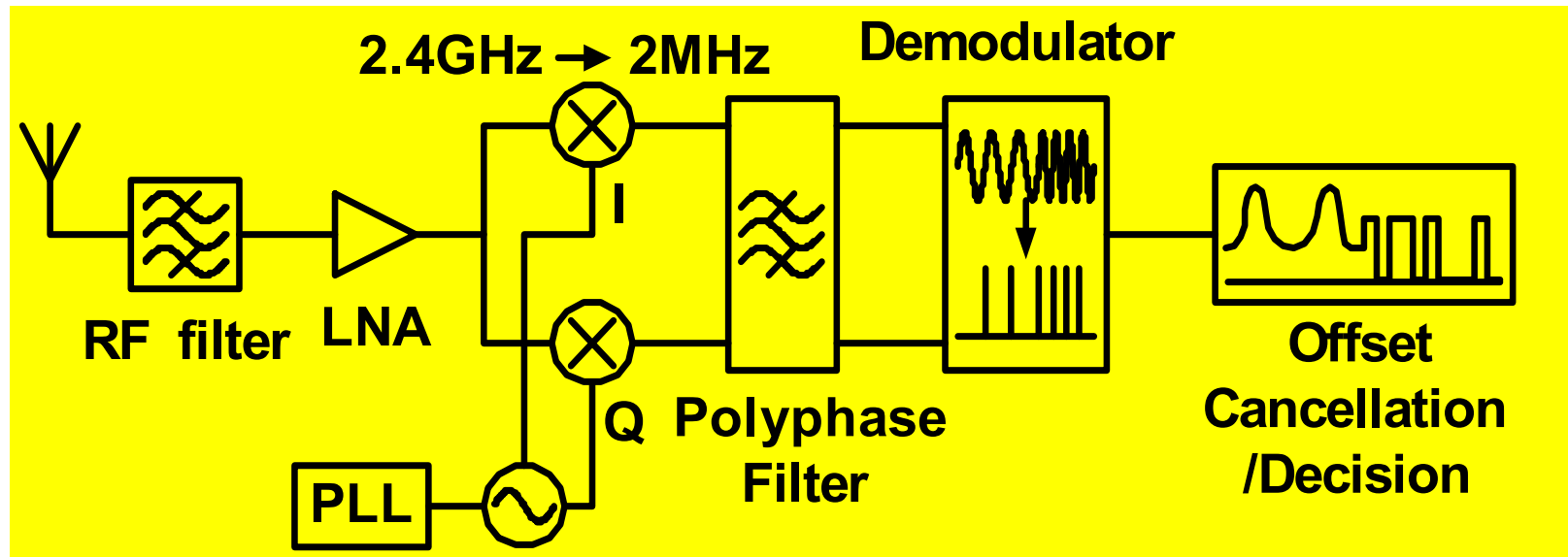

Developed in about 1 ½ years by:

Authors: Wenjun Sheng, Bo Xia, Ahmed Emira, Chunyu Xin, Ari Valero-Lopez, Sung Tae Moon and Edgar Sanchez-Sinencio.

# 0.35 $\mu$ m CMOS Bluetooth Low-IF Receiver IC

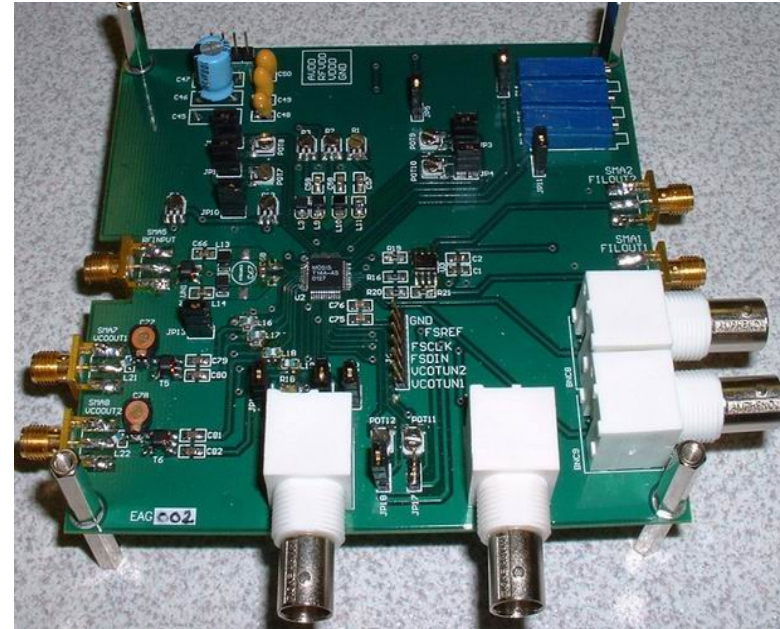
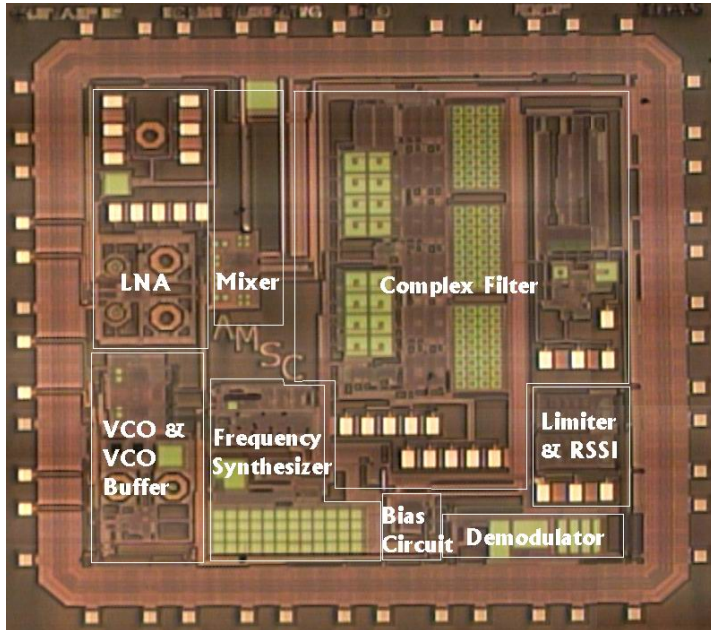

- Publications:

- 2002 RFIC Conference, Best Student Paper Award (third place).
- Journal of Solid-State Circuits: January 2003 (Receiver) and August 2003 (Demodulator).
- Transactions on Circuits and Systems – II: November 2003 (Complex Filter).



# TRANSCEIVER CELLULAR RADIO BLOCK DIAGRAM

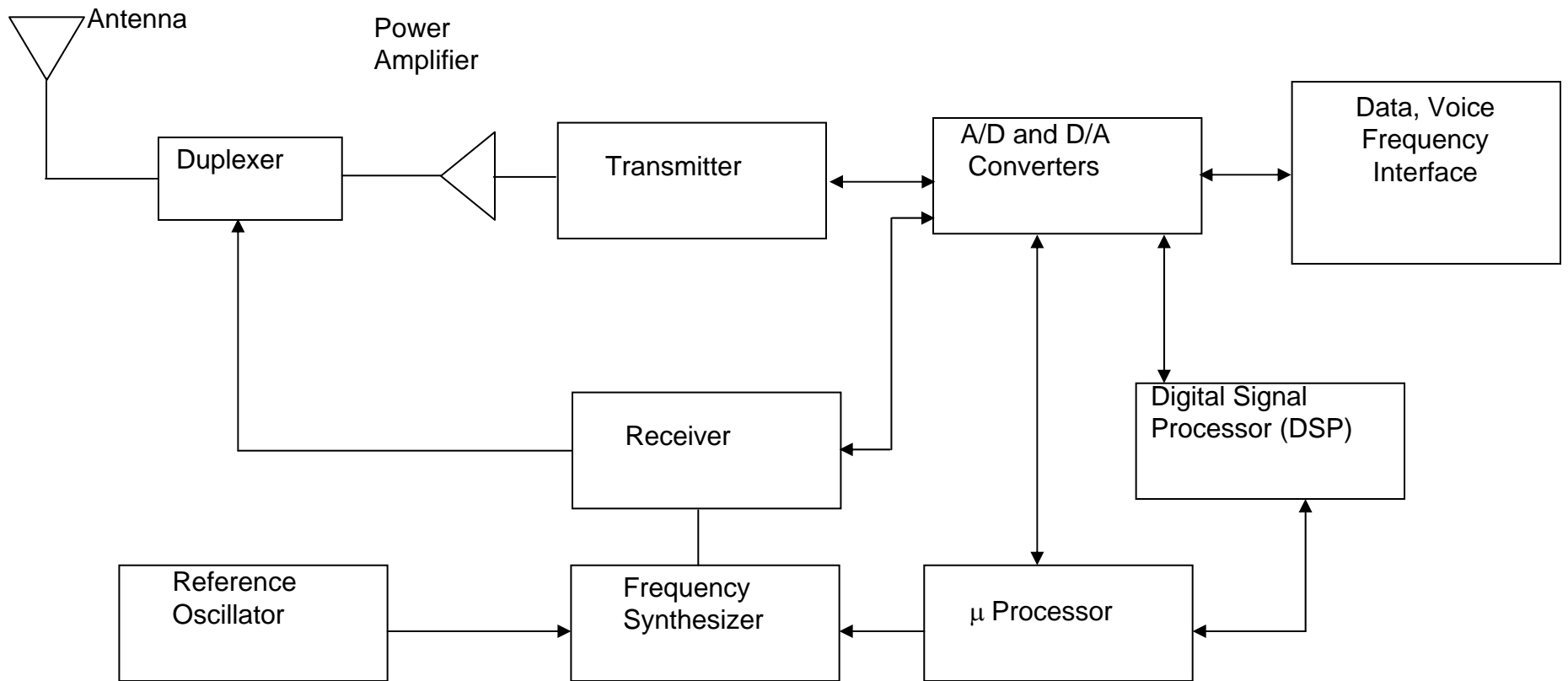

# GSM RECEIVER SYSTEM REQUIREMENTS

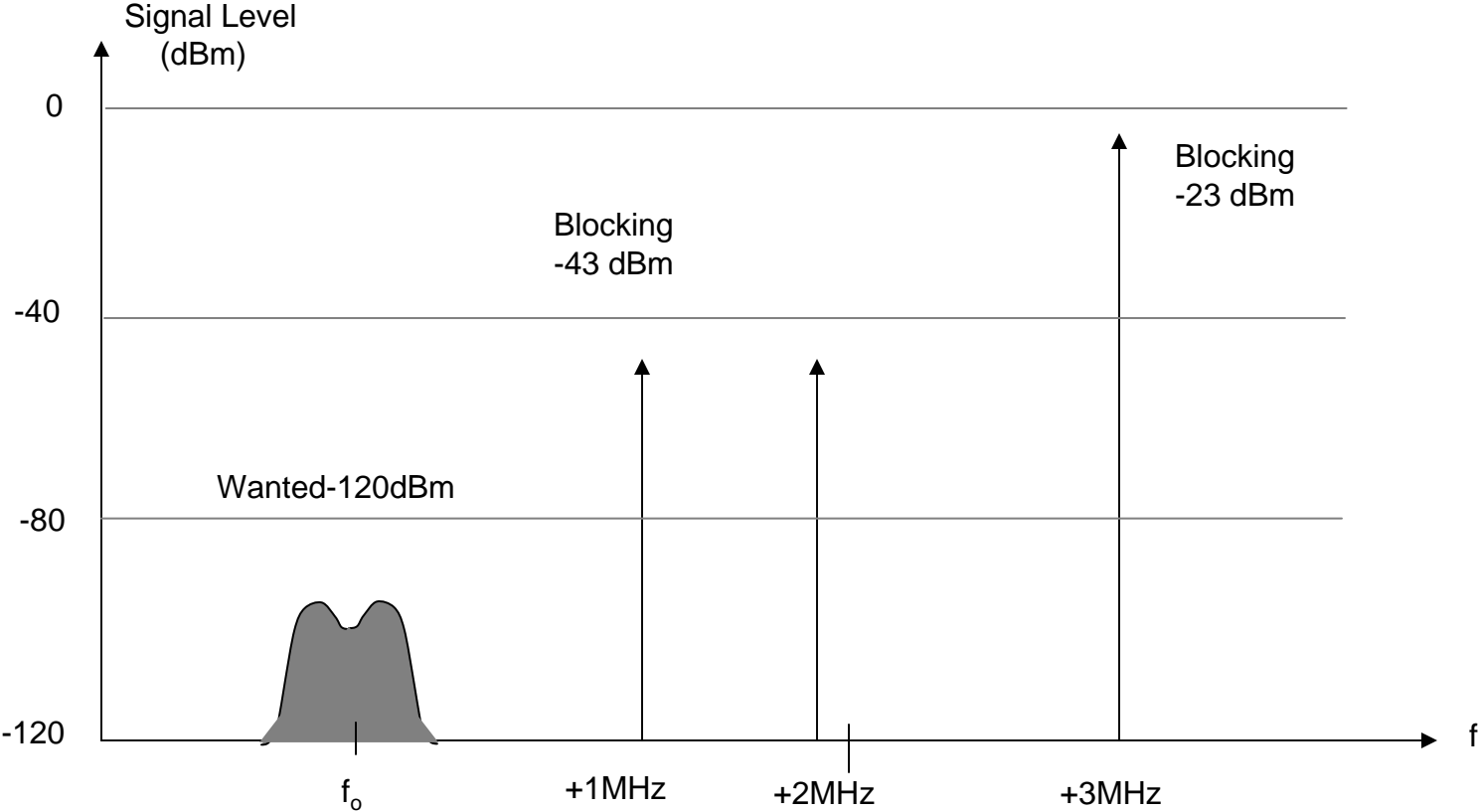

- ✓ Gain of wanted signal > 100 dB
- ✓ Noise Figure of LNA input less than 8 dB

# Subsampling Receiver

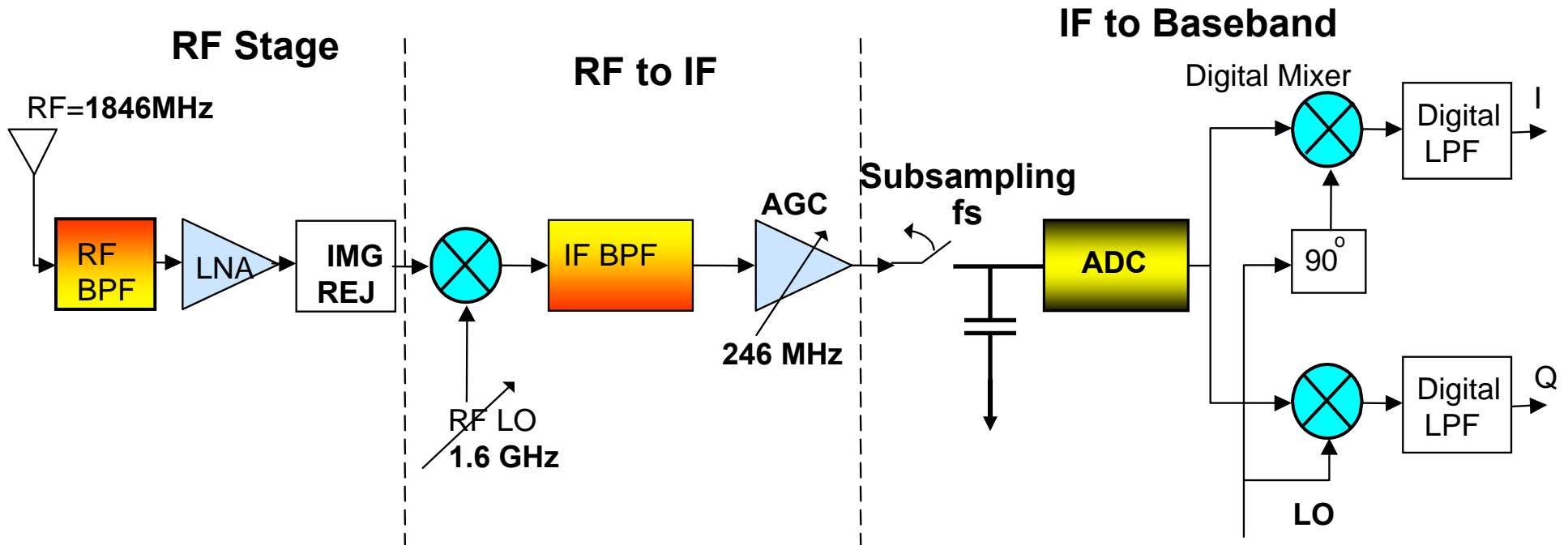

*Example: 1.8 GHz GSM Specifications: IF carrier frequency = 246 MHz,  
Channel BW = 200 KHz, Input Dynamic Range = 90 dB.*

- 2 digital low frequency mixers, no noise and distortion.
- Easier I&Q matching.
- No DC offset and  $1/f$  noise. Aliasing
- More digital means easier integration on a CMOS process.
- SNR degradation due to noise folding
- ADC & SH have to run at high clock to minimize noise folding.

# Sub-sampling Receiver: Basic Idea

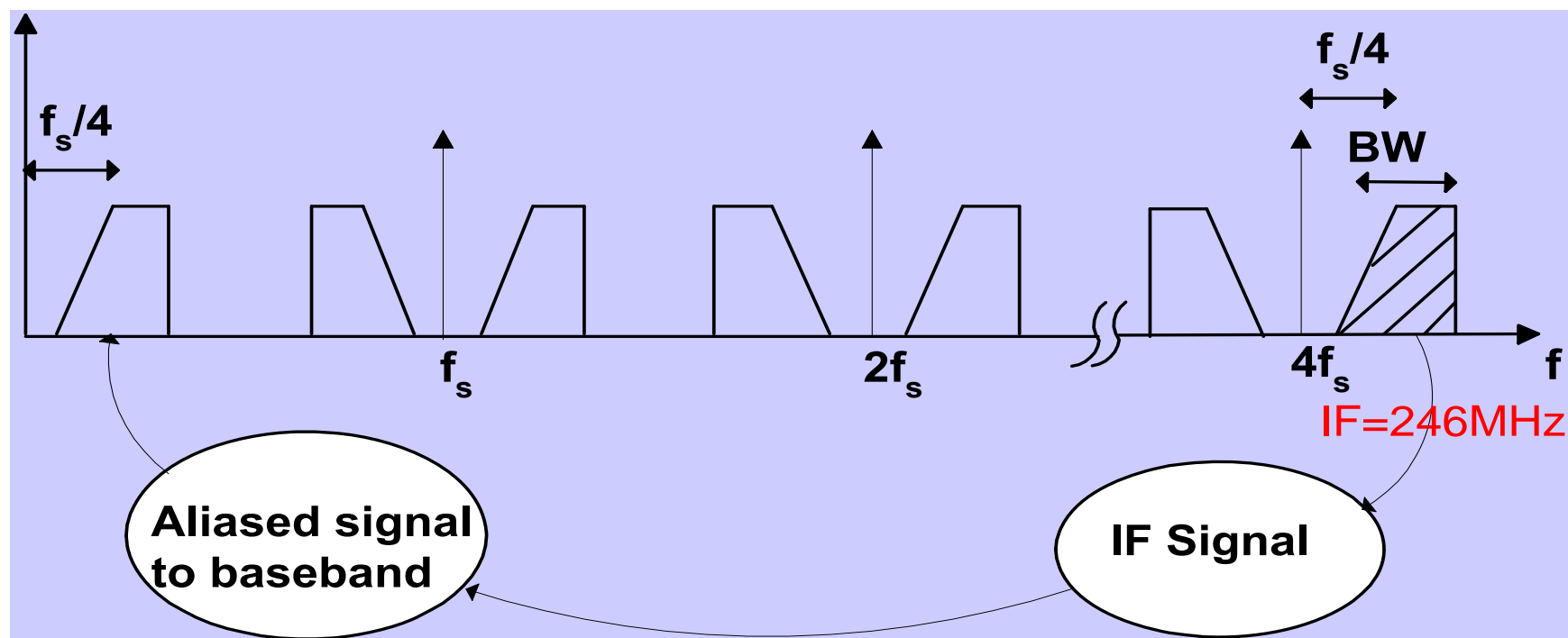

- The sampling rate,  $f_s$ , can be much less than the IF carrier.
- But,  $f_s > 2 \times BW$  must be satisfied (to avoid destructive aliasing).

# Examples of Standards (simplified versions)

	Bluetooth	802.11b (Wi-Fi)	HomeRF
Data rate	1Mb/s	1-11Mb/s	1Mb/s, 5Mb/s
Power	Lower	Higher	Variable
Modulation	FH-GFSK	DSSS-CCK	FH-GFSK
Frequency Band	2.401 – 2.48GHz	2.4 – 2.48GHz	2.401-2.480 GHz

## IEEE 802.15.4 (“Zigbee”)

Parameter	North America	North America	Europe
Frequency Range	2402-2480 MHz	902-928 MHz	2412-2472 MHz
Channel spacing	5 MHz	5 MHz	5 MHz
Multiple access method	CSMA/CA	CSMA/CS	TDMA
Duplex method	FDD	FDD	FDD
Users per channel	255	255	255
Modulation	OPQSK, BT=0.5	OPQSK, BT=0.5	GFSK, BT=0.5
Peak bit rate	250 kHz	40 kHz	250 KHz

Parameter	800 MHz	1900 MHz	Asia
Mobile-to-base frequency	824-849 MHz	1850-1910 MHz	1920-1980 MHz
Base-to-mobile frequency	869-894 MHz	1930-1990 MHz	2110-2170 MHz
Channel spacing	1250 kHz	1250 kHz	1250 kHz
Number of channels	20	48	48
Multiple access method	CDMA/FDM	CDMA/FDM	CDMA/FDM
Duplex method	FDD	FDD	FDD
Users per channel	More than 15	More than 15	More than 15
Modulation	QPKK/OQPSK	QPKK/OQPSK	QPKK/OQPSK
Channel bit rate (chip rate)	1.2288 Mb/s	1.2288 Mb/s	1.2288 Mb/s

# UMTS/DCS1800 Specifications

	DCS1800	UMTS
<b>Frequency Band</b>	1805 - 1880 MHz	2110 - 2170 MHz
<b>Channel BW</b>	200 kHz	5 MHz
<b>System Sensitivity</b>	-102 dBm	-117 dBm(@32ksps)
<b>BER</b>	1e-3	1e-3
<b>Blocking Characteristics</b>	600 - 800 kHz: -43 dBm	10 - 15 MHz: -56 dBm
	800 - 1600 kHz: -43 dBm	15 - 60 MHz: -44 dBm
	1600 - 3000 kHz: -33 dBm	60 - 85 MHz: -30 dBm
	> 3000 kHz: -26 dBm	> 85 MHz: -15 dBm
<b>Adjacent Channel Interference</b>	Cochannel: -9 dBc	
	200 kHz: 9 dBc	5 MHz: -52 dBm
	400 kHz: 41 dBc	
	600 kHz: 49 dBc	



# Multi-Channel, Multi-Mode Dynamic Range (1) DCS1800

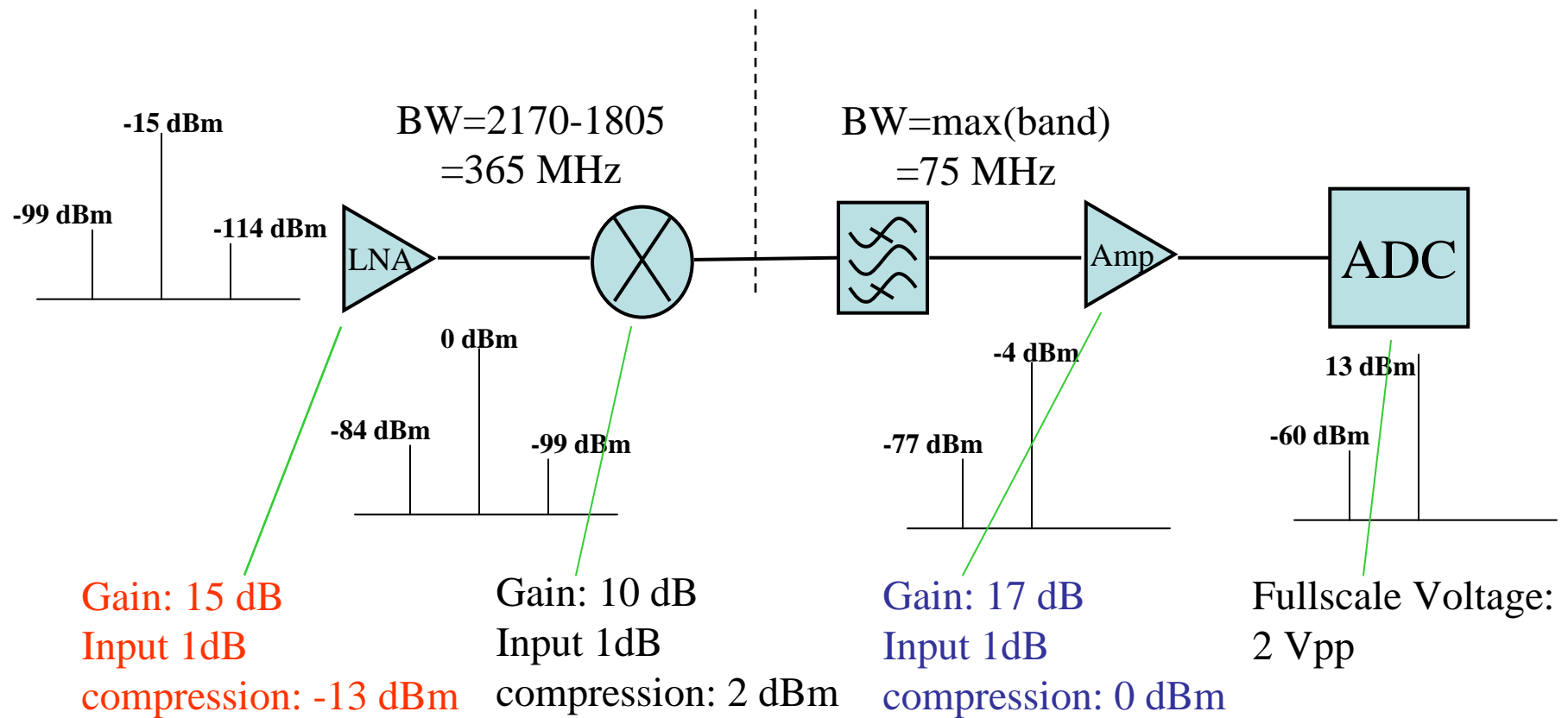

# Multi-Channel, Multi-Mode Dynamic Range (2) DCS1800

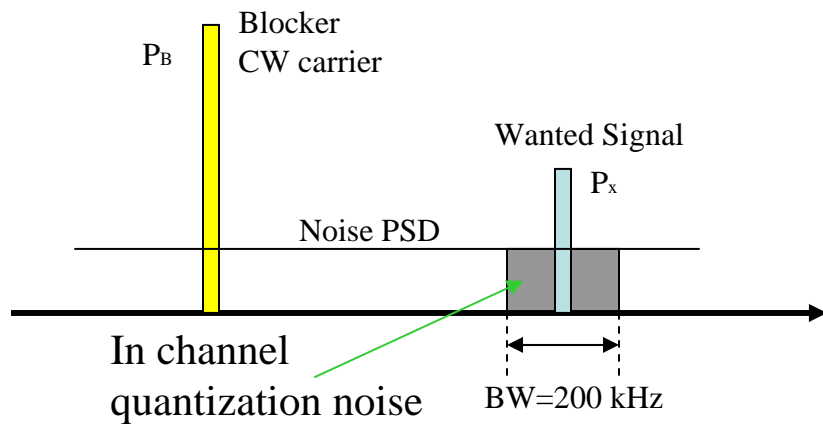

$$P_B = 13\text{ dBm}$$

$$P_x = -60\text{ dBm}$$

To ensure that the quantization noise power is negligible compared to that of interferers and other sources of thermal and device noise, choose

$$\text{SNR}_{\text{QF}} = 20\text{ dB}$$

With  $F_s = 150\text{ MHz}$ , calculated resolution of ADC is **11 bits**.

The SFDR (for single blocker) can be calculated by:

$$\text{SFDR} = P_B - P_x + \text{SNR}_{\text{QF}} = 93\text{ dB}$$

Required ADC Spec.:  $F_s \geq 150\text{ MHz}$ ,  $b = 11$ ,  $\text{SFDR} = 93\text{ dB}$

Current State of the art ADC:

$$F_s = 80\text{ MHz}, b = 14, \text{SFDR} = 100\text{ dB(AD6644)}$$

# Receiver Technology Trends

Traditional Superheterodyne

Increasing Integration

Borrows from handset chip integration,  
or new architecture like direct-conversion.

IF-Sampling/Digital I&Q

Reduces receiver size by eliminating IF stages  
New architectures using more digital processing

Multi-mode, Wideband

Large reduction in receiver size  
Major architectures shift to DSP-intensive radio, highly programmable

# Software Receiver

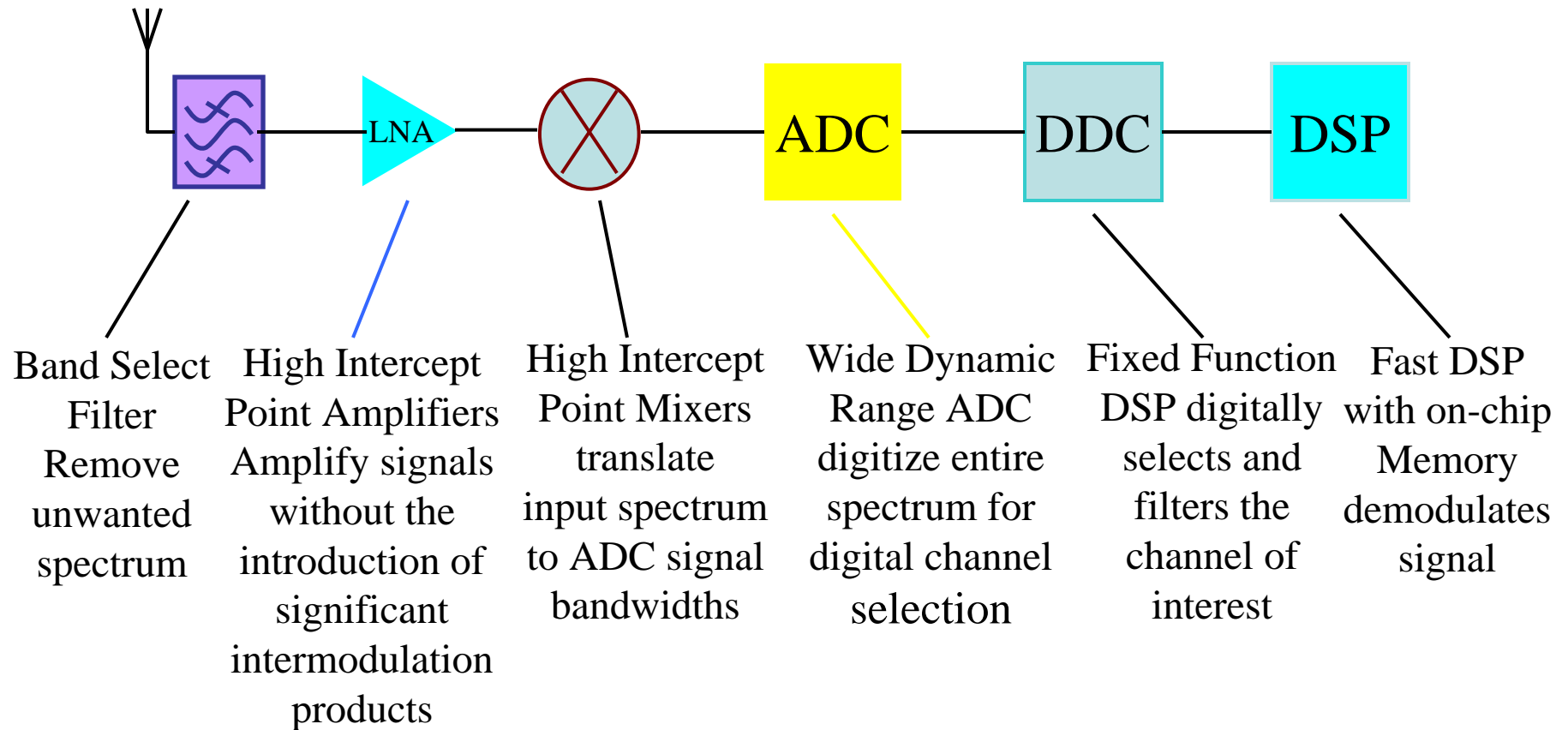

# TRADITIONAL RADIO[3]

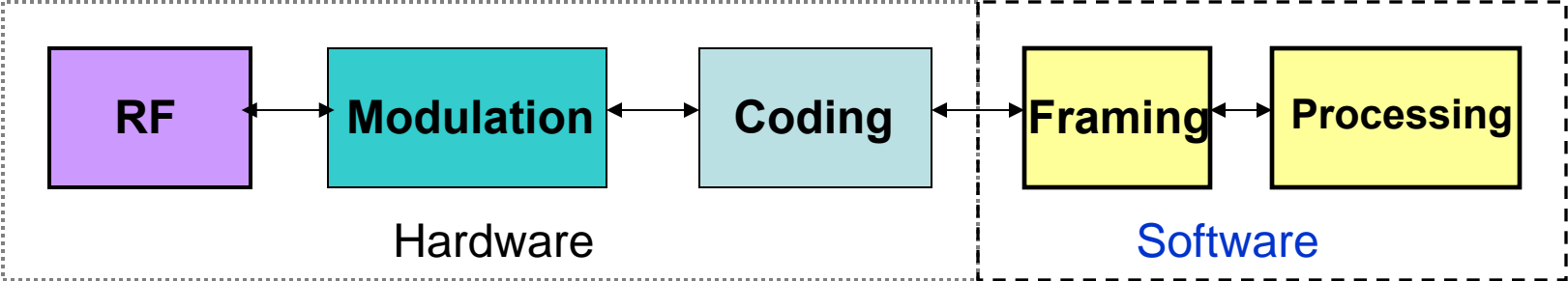

# SOFTWARE RADIO

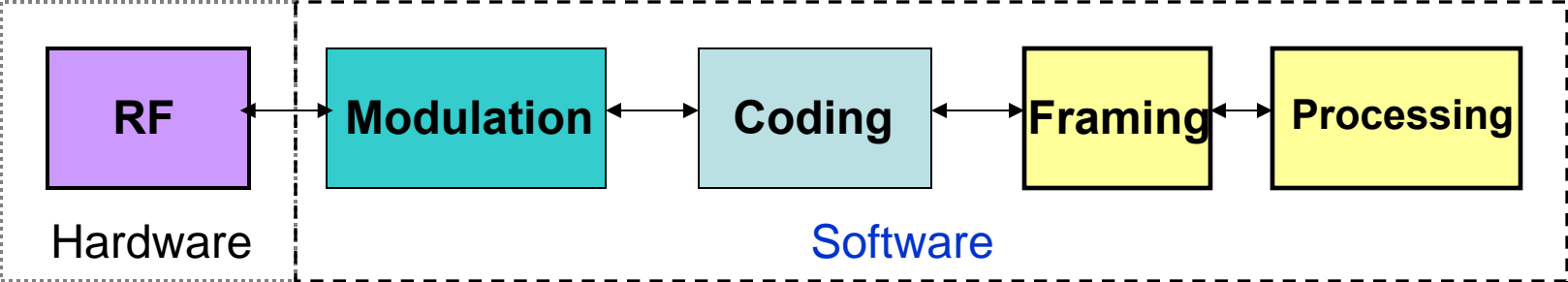

# COGNITIVE RADIO

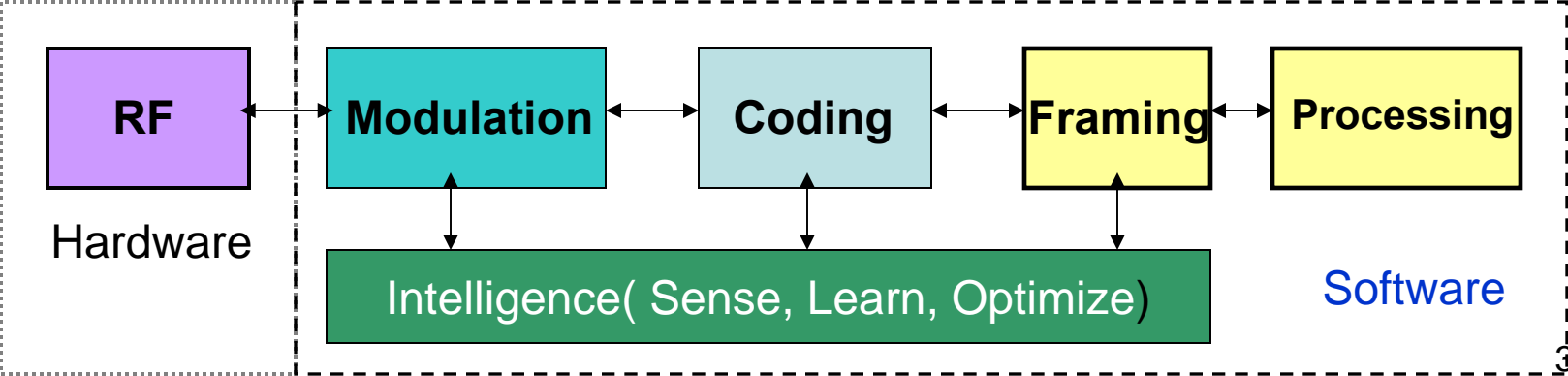

# SOFTWARE RADIO

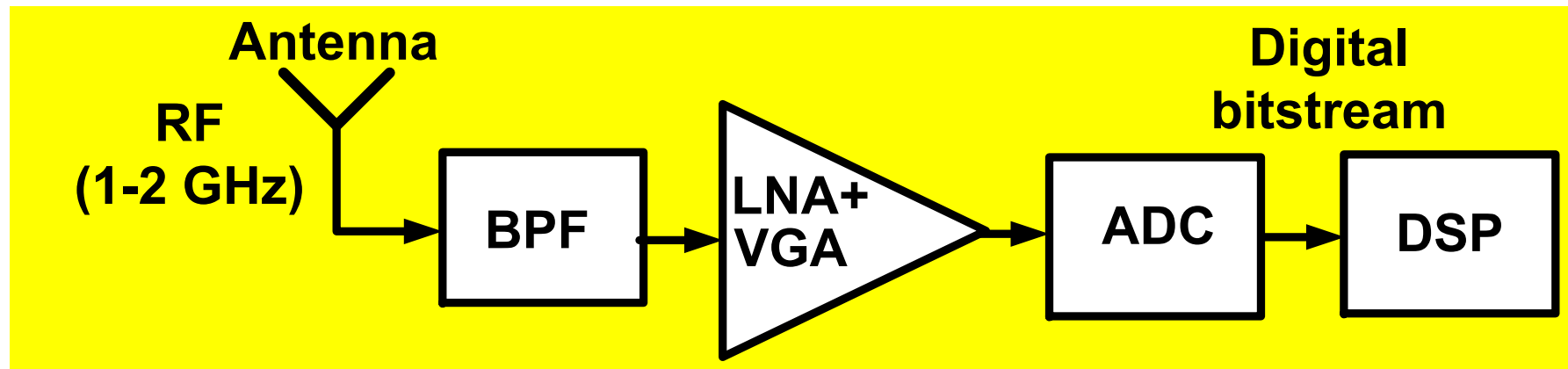

- Idea introduced in 1991 by Joe Mitola
- Direct RF digitization
- Single / multiple channels sets ADC BW
- Reconfiguration by DSP software programs

# SOFTWARE DEFINED RADIO

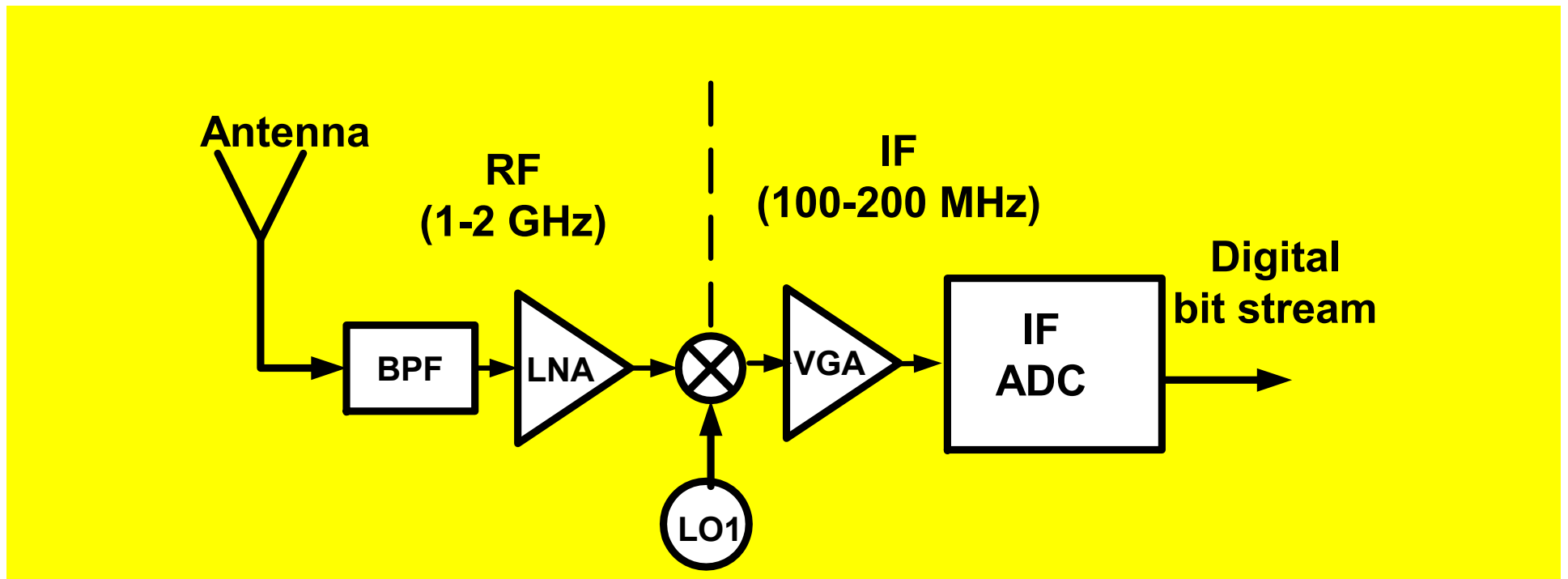

- IF digitization
- No specific standard for IF location
- Reduced DC offset, flicker noise problems

# Literature survey

Ref	Type	Fo GHz	Fs GHz	SNR 1 MHz BW	Power (mW)	Tech
Vessal (JSSC 04)	Nyquist (FI)	0 - 0.7	2	48 dB	×3500	SiGe HBT
Kaplan (CICC 03)	CT BP $\Sigma\Delta$	1.3	4.3	✓62 dB	×6200	InP HBT
Chandrasekaran (CICC 02)	SC LP $\Sigma\Delta$ with mixer	0.9	0.1	25 dB (bad SNDR)	30	0.25 $\mu$ m CMOS
Cherry (TCAS 2000)	CT BP $\Sigma\Delta$	1	4	51 dB	450	0.5 $\mu$ m SiGe
Gao (VLSI 98)	CT BP $\Sigma\Delta$	1	4	48 dB	350	0.5 $\mu$ m SiGe
Jayaraman (GaAs 97)	CT BP $\Sigma\Delta$	0.8	3.2	55 dB	1800	GaAs



# REFERENCES

- [1] P-I. Mak, S-P U, and R.P Martins,” Transceiver Architecture Selection: Review, State-of-the-Art Survey and Case Study”, *IEEE Circuits and Systems Magazine*, vol. 7, No. 2,pp. 6-25 Second Quarter 2007
- [2] T. Lee, *The Design of CMOS Radio Frequency Integrated Circuits*, Cambridge University Press, 1998.
- [3] A. Baker, S. Ghosh, , A. Kumar, and M. Bayoumi, “ LDPC Decoder: A Cognitive Radio Perspective for neXt Generation (XG) Communication,”, *IEEE Circuits and Systems Magazine*, vol. 7, No. 3,pp. 24-37, Third Quarter 2007
- [4] B. Razavi, *RF Microelectronics*, Prentice Hall, Upple Saddle River,NJ 1998
- [5] A. Bensky, “ Short-range Wireless Communication: Fundamentals of RF System Design and Application”, 2<sup>nd</sup> Edition, Amsterdam, -Newnes-Elsevier 2004
- [6] W. Sheng, Bo Xia, A.E., Emira, C. Xin, A.Y Valero-Lopez,, Sung Tae Moon, E. Sanchez-Sinencio, "[A 3-V, 0.35-/spl mu/m CMOS Bluetooth receiver IC](#)", *IEEE Journal of Solid-State Circuits* , Volume: 38 Issue: 1 , Jan 2003, Page(s): 30 -42
- [7] A. Emira, A. Valdes-Garcia, B. Xia, A. N. Mohieldin, A. Y. Valero-Lopez, S. T. Moon, C, Xin, and E. Sanchez-Sinencio.; "[A Dual Mode 802.11b/Bluetooth Receiver in 0.25um BiCMOS](#)", *IEEE International Solid-State Circuits conference*, pp. 153-154 San Francisco, February , 2004.