

Active Filter Design Implementations

Recent and Future Approaches

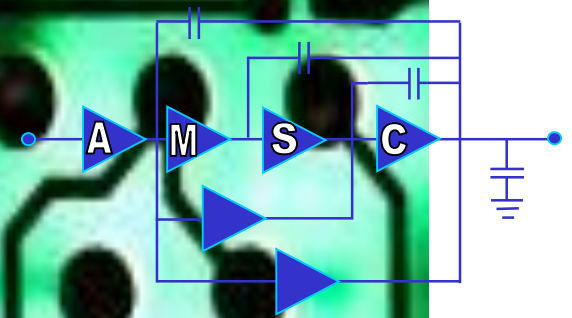

Dr. Edgar Sánchez-Sinencio

18E WERC,

(845-7498

Th 2:20-3:35pm

TB 1003

-Sanchez@tamu.ed

Hours: M W 1:00-2:25 pm

Analog and Mixed-Signal Center (AMSC), TAMU

GOALS



- 1. To understand and design CMOS active filters. Emphasize the integrated circuit design aspects of practical filters for a host of applications and frequency ranges.**
- 2. To use properly the filter approximation suitable for each particular application.**
- 3. To identify tradeoffs of filter implementation types such as Active-RC, OTA-C, Gm-C, Active-R, Ring Oscillator integrator based and Switched-Capacitor. Trade-offs of performance, design simplicity and cost will be explored.**

INTRODUCTION



- Electronic Filters are fundamental elements in the majority of applications such as Base band receivers, consumer electronics, sensor interfaces, oscillators, PLL, hearing aids, switching converter loop control, and audio amplifiers among many others.
- The main topics are filter approximation, filter topology and circuit implementations. Selection of approximations and filter topologies and implementations are very much application dependent.

Evolution of Analog Filters

- **Motivation and historical background**

Before 1974

- Passive LC type
- Discrete Active-RC
- Thin Film Hybrid Integrated Circuits

- **Monolithic Filters (After 1980)**

- MOSFET-C, - Transconductance- Capacitor (OTA-C), - Switched-Capacitor, - Switched Current (SI), Log-Domain

- **RF Integrated Filter (After 1996)**

- Active RLC prototype



Continuous-Time Filters beyond the conventional active-RC and Gm-C are the following filter implementations:

Active-R

Switched-R

Ring Oscillator Based

PWM Based

Inverter Based OTA-C

These filters have been revisited or proposed in the last few years.

Advantages and disadvantages on these filter implementation as well as power, area, linearity, and noise tradeoffs determine the selection of the implementation.

Baseband filters required in Receiver have to continuously evolved to meet new Communication Standards.

Filters Historical Background

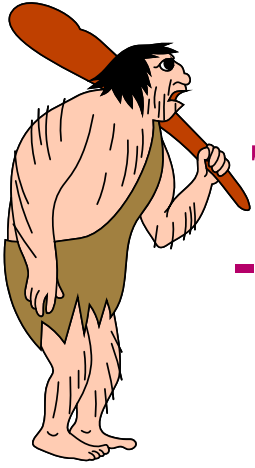

The early years

- The origin of electronic filters dates back to 1915 when K.W. Wagner and G.R. Cambell from Germany and USA, respectively introduced passive electric wave filters to meet the needs of the young communications industry.
- One of the major applications of the passive lumped filter has been in the design and implementation of channel bank filters in frequency-division multiplex (FDM) telephone system.

Historical Background

The early years

- From the early 1920s to the latter 1960s the majority of voice-frequency filters were realized as discrete RLC networks.
- In the 1950s, a goal to reduce the size and cost of inductors by replacing them by active circuits was launched. That is, the design of inductorless filters.
- The first book on Active RC filters was: L.P. Huelsman, “ Theory and Design of Active RC Circuits, Mc Graw-Hill Book co., NY 1968.
- Early 1970s Thin-film hybrid integrated circuits were developed.

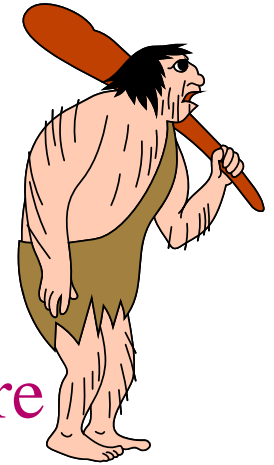

Historical Background

Development of good quality active components

- John Ambrose Fleming, in 1904, files a patent for the vacuum tube (diode)
- Lee De Forest, in 1907, and R. Von Lieben invented the amplifier vacuum tube (triode). Five years later in 1912 he developed the audion amplifier with a gain of 120 v/v.
- Eccles and Jordan in 1919 invented the flip-flop circuit, a key component for computers in the 40's.
- In 1948, Bardeen, Brattain and Schockley discovered the transistor.
- Gordon Teal at Texas Instruments, in 1954, introduces the silicon transistor, which is much cheaper to produce

Development of good quality active components

- In 1958, J. Kilby and R. Noyce separately invented the integrated circuit. In 1970, RCA introduced the MOS technology for the fabrication of IC.
- In 2000, J. Kilby receive the Nobel Prize in Physics for his work in Integrated Circuits.

Historical Background

Development of good quality active components

- Early Op Amps in the 1940s were implemented with vacuum tubes.
- The first monolithic silicon Op Amp was developed in the early 1960's by Robert J. Widlar at Fairchild.
- In 1968 the popular uA 741 Op Amp become the industrial standard.
- Today, the cost of a general purpose Op Amp is less than the price of a cup of coffee.
- The Operational Transconductance Amplifier (OTA) was first fabricated by RCA in 1969.

Historical Background

Development of active filters

Since Op Amps were expensive components, the first active filters used architectures with only one Op Amp for Biquadratic Filters.

It is interesting to note that current RF filters due to the limited allowable power consumption they use only few transistors as the active components, and the rest of the filters involve passive components such R, L and Cs. Research for this type of low power, high frequency filters is currently in progress.

Historical Background (cont.)

Development of Monolithic Analog Filters

- Due to the difficulty in making fully integrated resistors, in the 70s the active RC filters were not able to fabrication in monolithic form on one silicon chip.
- Practical Switched-Capacitor filters characterized in the Z-domain were developed in the late 70s* and earlier 80s. SC filters have good accuracy compared with continuous-time filters.

* D. L. Fried, "Analog sample-data filters," IEEE J. Solid-State Circuits (Corresp.), vol. SC-7, pp. 302-304, Aug. 1972.

Historical Background (cont.)

- The origin of the SC principle was first reported by Maxwell around 1873.
- The first reported Switched Capacitor filters appeared in the IEEE JSSC in December 1977 by Berkeley* and Carleton** Universities
- The first book fully dedicated to Switched- Capacitor was published in 1984. P.E. Allen and E. Sánchez-Sinencio, “ Switched Capacitor Circuits,” Van Nostrand Reinhold, NY, 1984.

*B. Hosticka, R.W. Brodersen, and P.R. Gray. “MOS sampled data recursive filters using switched capacitor integrators” *IEEE JSSC* vol. 12, No. 6, pp 600-608, December 1977

**J.T. Caves, S.D. Rosembaum, M.A. Copeland, C.F. Rahim, “Sampled Analog filtering using switched capacitors as resistor equivalents,” *IEEE J. of Solid State Circuits*, vol. 12, No. 6, pp 592 – 599, Dec. 1977

Historical Background (cont.)

was published in 1984 by P.E. Allen and E. Sánchez-Sinencio, “Switched Capacitor Circuits,” Van Nostrand Reinhold, NY, 1984.

- Switched-Current filters searching for reduced complexity and higher speed were proposed in the late 80s and early 90s.
- By substituting R_s in Active RC Filters the MOSFET-C Filters were born around 1985.
- A nonconventional approach using transconductance amplifiers in open loop and capacitors the OTA-C Filters were developed in the middle 80s.

Historical Background (cont.)

Development of Monolithic Filters

- Current-mode filters using simple transconductors (transistors) and current-mirrors were developed in 92.
- RF filters are revisited in the last 5 years, search for on chip inductors is vital.
- Log domain filters for high tunability and low voltage supply were also investigated



Monolithic Integrated Filters

CONTINUOUS-TIME FILTERS:

Active RC
OTA-C
Active-R
CURRENT-MODE
RING OSCILLATOR BASED

SAMPLED-DATA FILTERS

- SWITCHED -CAPACITOR
- SWITCHED – CURRENT
- SWITCHED-R
- PWM BASED FILTER

+ DIGITAL

RF- FILTERS

- BIPOLAR
- CMOS
- SiGe

HARD DISK DRIVE, **SIGMA DELTA ADCs**, TRANSCEIVERS, MEDICAL, HEARING AIDS AND SENSORS APPLICATIONS

Active R-C Filters

- This approach is inspired on passive filters. Passive filters are mainly composed by R, C, L (and often with transformers).
- A large number of contributions dealing with passive filters and mathematical approximation satisfying the filter specifications were developed in the 30's and 40's.
- Passive filters are not suitable for audio applications due to the bulky inductors required. Thus other alternatives were investigated in the 60's and 70's
- Before the invention of transistors and Op Amps, passive filters were the dominant technology used from audio to microwave applications. They are back for specs requiring high linearity. See ADSL and hard-drive applications.
- Thus the inductor, in the passive filters, was replaced by a circuit capable to emulate it, for frequencies below a few hundred of MHz.

Active R-C Filters (cont.)

- A host of approaches for active-RC were developed among them:
 1. Substitute the inductors by active simulators composed of Op Amps, Rs, and Cs.
 - 2.a)- Emulate the equations of the RLC filter
(Leap Frog Realization)
 - b)- Emulate transformers in a RLC-transformer prototype.
 3. Convert the passive filter into a filter consisting of frequency dependent negative resistors (FDNR)
 4. Based on State-variable techniques.

MOSFET-C Filters

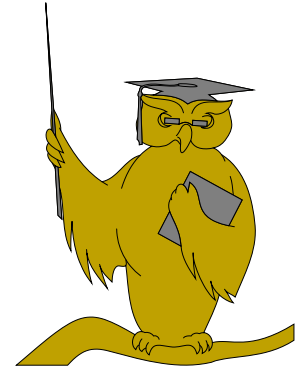

- In this approach an active-RC filter is transformed into a MOSFET-C filter. The basic transformation is obtained by substituting resistors in the original active-RC filter prototype by MOS transistors.
- The advantage is that the transformed filter can easily be integrated. Most of the properties of the original filter prototype are retained by the MOSFET-C filter. The time and frequency response ideally remained the same.
- Drawbacks are the nonlinearity introduced by the MOSFET, as well as the maximum peak swing limited by the tuning voltage.

SWITCHED-R Filters

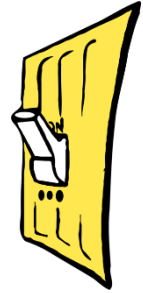

- In this approach an active-RC filter is transformed into a switched-R filter. The basic transformation is obtained by substituting resistors in the original active-RC filter prototype by a switched-R.
- The advantage is that the transformed filter can easily be tuned digitally. Most of the properties of the original filter prototype are preserved. The time and frequency response depend on the duty cycle (D) of the switched-Rs.
- Drawbacks are the nonlinearity introduced by the clock signal of the switched-R, as well as stricter Op Amp requirements.



OTA-C Filters

- In contrast to MOSFET-C Filters, **OTA-C Filters** operate in open loop fashion. The design parameters are the capacitors and the transconductance gains. $OTA-C = G_m-C$
- In principle, tuning and swing can be made independent from each other. G_m-C might be better than MOSFET-C since no fundamental limit exists for its maximum swing.
- G_m-C operate at higher frequency due to the limited internal high impedances nodes.

Continuous-Time Current-Mode Filters

- High-frequency and low voltage applications motivated researchers to search for alternative filter design style.
- Groups at Texas A&M University and Carnegie Mellon, in 1991 independently developed an approach based on current-mirrors and simple transconductors (one driven transistor) capable to operate at frequencies up to fundamental limits of the MOSFET.
- Due to the small voltage swings, and low bias overhead requirements, current-mode filters work well with a 1.8 V supply
- This technique is well suited to standard digital CMOS processes



Continuous-Time Filter Properties

- Transconductance- and current-mode filters are suitable for high-speed, reduced silicon area and moderate accuracy.
- Read Channel filters are examples of practical Gm-C filters
- However, due to process and temperature variations, these filters require tuning circuitry. Frequency tuning has been accomplished within 1% accuracy. This is not the case for Q-tuning for $Q > 5$, where only a modest 25 to 30% accuracy has been reached, until recently where a 1% accuracy was obtained.
- Practical Q-tuning is still a difficult problem.

Switched-Capacitor Filters

- Switched-Capacitor (SC) techniques , led to the first use of fully integrated complementary metal oxide semiconductor (CMOS) . The fact that MOSFET, Cs together with Op Amps can be mass produced on silicon led to a breakthrough in active filter design.
- SC filters operate on the principle of transferring analog signal samples (represented as charges on capacitors) from one storage element to another
- SC advantages are the accuracy, and digital programming.

Switched-Capacitor Filters

- The time constant associated with RC of active filters can be expressed as follows:

$$T_c = R_{eq}C = (T/C_r)C = (C/C_r)(1/f_s)$$

T_c is the time constant, the equivalent resistor (R_{eq}) is equal to the sampling period divided by a capacitor C_r . Accuracy of T_c is better than 0.1%

- We will explore how to design high-Q SC Biquad filters, and ladder filters.

CMOS Switch implementation and low voltage effects in deep submicron technologies

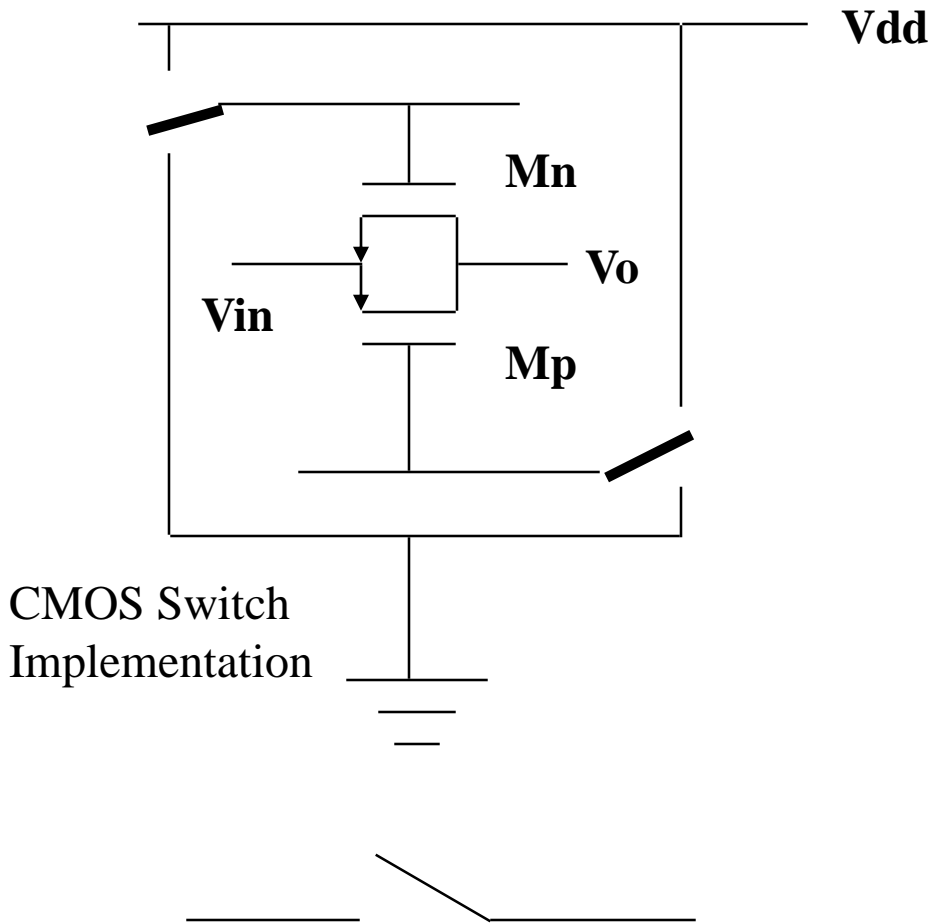

Switch representation

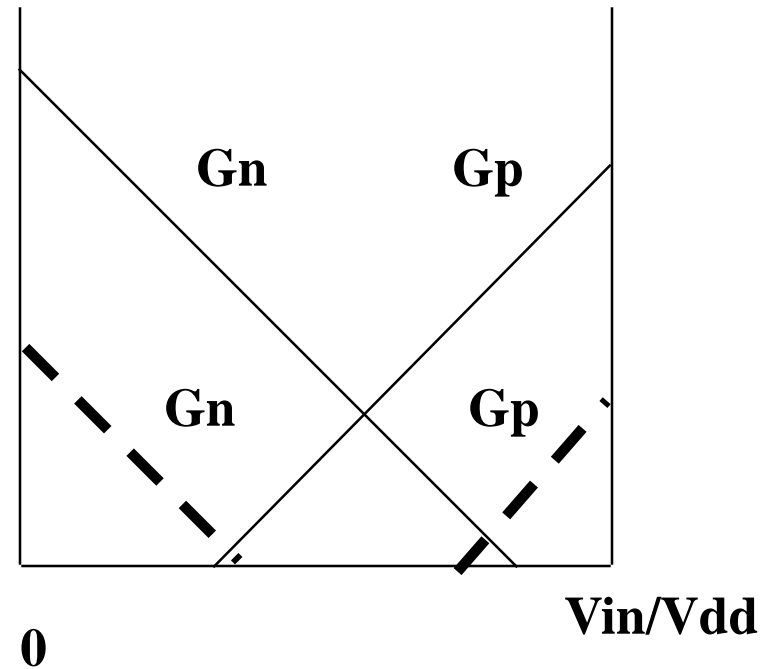

On-conductance CMOS switch vs. drain (source) voltage for different V_{dd}

How to tackle the limitations of switches for low power supply ?

- Clock voltage multiplication, i.e., charge pump, supply voltage doubler
- Multiple threshold values process technology, (Low V_t for switches)
- Switched Op amps

Remarks on Filters

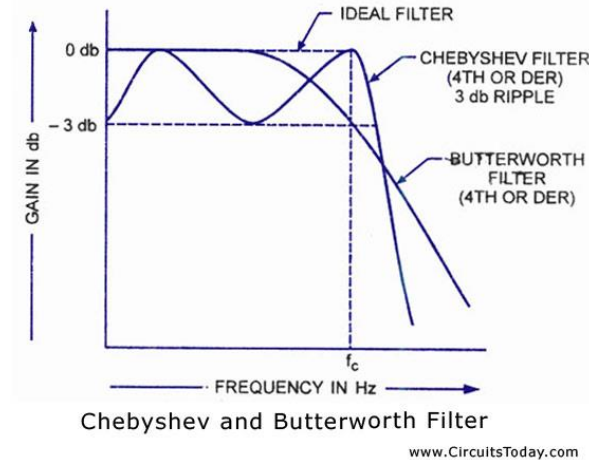

- Active filters are playing and will play a key role in innovative and commercial products (including wireless products) dealing with both analog and digital circuits, the so called mixed-mode signal circuits.
- The study of Active-Filters basically involves:
 - Filter approximation (mathematical expression that satisfies the design specifications)
 - Filter Topologies (i.e., Cascade, Leapfrog, State-Variable, Primary Resonator block) .
 - Macromodeling of systems, blocks and circuits.
 - CMOS Implementations and design trade-offs
 - Effects of the non-idealities of the filter components
 - Sound *testing Lab set-up*, in particular for high-frequency applications.

ECEN 622
(ESS)
ACTIVE
FILTER
SYNTHESIS



What should we know at the end
of the course?

What are the fundamental concepts
that are practically time-invariant?



- How old is the theory of filters and why is still important?
- What are the types of filter used in integrated circuits?
-Passive, active, continuous-time, discrete time, linear
- How can we mathematically express the filter transfer functions? What is the difference between synthesis and analysis?
- Are there different filter expressions that meet the same filter requirements ?



- Why filters are implemented using different methodologies such as active-RC, Switched-capacitors, OTA-C, active LC, Active-R, Switched-R?
- Can we use the same mathematical descriptions to deal with a discrete-time filter and continuous-time filter?
- Are these filter implementations accurate?
- Can inaccuracies on the filter performance be alleviated, how?



- Can one design a bandpass filter using only Rs and Cs ?
- What are the implications to have real poles or complex poles in a filter transfer function?
- What are complex filters and where are they used?
- What are adaptive filters?
- What filters are typically used in receivers?



- What are the application areas where filters are used?
- Are digital filters eliminating the use of analog ones?
- What are the filter design trade-offs and why are they of practical interest?
- Do you know how many companies use filters in their products?
- How often are papers published on filters and since when?
- What are the main areas related to patent filters?

- What are the complementary fields to study filters?

- Control systems dealing with stability and adaptive systems.

- Communications dealing with standards, modulation and system level design.

- Microwave Circuits dealing with transmission lines, matching networks and antennas.

- Process technology and modeling that limit the filter performance.

- Digital Signal Processing to tune analog components