

ACOUSTIC NAVIGATION FOR MOBILE ROBOTS
Critical Design Review

Josh Earley
Trent Foley
Thomas Garner
Chris Gonzales

CPSC 483 – Spring 2003

3 MAR 2003

Table of Contents

Introduction.....	pg.3
Current Design	pg.3
Changes from Proposal	pg.4
Current Design Problems	pg.5
Future Design/Implementation Issues.....	pg.7
PCB Generation	pg.8
Robot	pg.8
Scheduling/Order Status.....	pg.8
Future Plans	pg.9

Introduction

Our design project is going according to plan. We have already ordered a majority of the major parts and are working diligently on the final aspects of our design. Our parts have begun arriving and we are beginning the testing phase. Below is an outline of our status concerning different aspects of the design, as well as an update on our scheduling, cost, and new implementations that differ from our original proposal.

Current Design

Figure 1 illustrates our current design. We have decided to fabricate two separate printed circuit boards: one for the microphone array itself and one for the microcontroller. This will allow us more modularity and ease of maintenance and fabrication. The microphone array board will consist of the 8 microphones patterned in such a way that each microphone has 45° of coverage. Further, the board will have the resistors and capacitors that develop the output signal for each microphone. We will route the signals to the microcontroller board via a 10-pin connector: 8 pins for the microphone signals, 1 pin for Vcc, and 1 pin for ground. The microcontroller prepares the microphone signal to be presented to the microprocessor of the Mark III. This board will accept the eight microphones data into an 8:1 multiplexor that is controlled by the Mark III's processor. Once a microphone is selected, it will be sent to the filter (LMF100). The filter has two inputs, one for the microphone data and one from the crystal and 4-bit counter (74LS191) circuit, which will provide 8 center frequencies through a processor controlled 8:1 multiplexor. After the filter, the signal will be rectified and sent to the A/D

converter (ADC0801). This will convert the rectified signal into an 8-bit digital signal that is sent to the processor. In all, we will use 14 interface bits on the Mark III. Six bits will be used for the multiplexors, and eight bits will be used for the microphone signal. However, we also have the capability to send the microphone signal to the processor in analog format, since the Mark III has 4 analog inputs onboard that route to analog-to-digital converters.

Changes from our proposed design

The most critical changes from our proposed design is that we have decided to use a switched-capacitor filter as opposed to the static low and high pass filters in the original design. This will allow us to utilize an efficient bandpass filtering system which we can dynamically control the center frequency from the processor of the Mark III. The filter that our team chose is the LMF100 from National Semiconductor (Figure 2). It is operable with a single power supply and offers many modes of simultaneous filtering. The LMF100 datasheet details how to configure the device for our needs. With this change in filtering design from our proposed design, a clock, counters, and 8:1 digital multiplexer will be additionally required. The clock will drive the counter, so that the clock signal will be halved at each bit, granting lower frequencies. These frequencies from the clock will then be multiplexed to be the clock input to the LMF100 filter. The eight center frequencies are 5 kHz, 2.5 kHz, 1.25 kHz, 625 Hz, 312.5 Hz, 156.5 Hz, 78.12 Hz, and 39.06 Hz as shown in Figure 3. This will give us a broad range to test and demonstrate the tracking abilities of our design.

Another aspect of our design that changed was that we switched microphone sampling control from the hardwired circuit to the processor, which allows us greater flexibility in monitoring a specific microphone. In our proposal, we constantly polled each microphone in a

loop based on the time specified by our clock. By using the processor we are now able to select a certain microphone at any time.

Our original proposal also stated that we would be using the Motorola Coldfire UART. However, we have decided to use the Mark III robot (Figure 4). It is small, expandable, and is serial port programmable. One of the main reasons that we chose this robot is that it is much cheaper than other robots we were considering. Also, our advisors had recommended we go with the Mark III because many of the other design groups were using Boebots. This robot also features both analog and digital inputs which could possibly be used to bypass the need for A/D converters in our initial design. Unlike other robots we looked at, the Mark III is programmable in C or Java. We also purchased an upgrade for the robot that includes OOPicII+ and more memory. The robot has already been ordered and we should receive it soon.

Lastly, we chose to have 8-bit resolution for our microphone signal as opposed to our original proposal of 4-bit resolution. The main reason for this is due to the fact that the Mark III gives us a more robust I/O interface.

Current Design Problems

Sinusoidal Signal Rectification

In order to aid in the design of the rectifier, we modeled both a half-wave and full-wave rectifier coupled with a low-pass filter using PSpice. We started with the simplest forms of each of these rectifiers, tweaked resistance and capacitance values, and attempted to model the behavior of the input signal as close to that of our microphones output. The following is an overview of what we encountered during the process.

Two problems/questions we ran into during the simulations were:

1. What exactly is the behavior of the microphone signal going to resemble?
2. How can we simulate this behavior in PSpice?

For the first issue, we decided that in order to get a better idea of the signal, we would need to physically test our microphones with an oscilloscope. We were assuming that the signal generated would be a sinusoid around a constant dc voltage (V_{ref}), oscillating anywhere between ground and $2*V_{ref}$.

Concerning how to simulate this signal, we used a sinusoidal frequency modulating voltage source and altered its parameters to test different frequencies and signal levels. This could be a valid method depending on whether our assumptions about the microphone signal above are correct. Otherwise, we will have to derive other methods to simulate the behavior.

Half wave rectifier

The half wave rectifier proved to be a more feasible solution over the full wave rectifier. It is a very simple design and it accomplishes what we need. Figure 5 shows our half-wave rectifier model. Figure 6 shows the voltage relationships between the input and output signals with a constant 4V signal around 400 Hz. The green line is the rectified output, and the red line is the simulated microphone input signal. Figure 7 shows the voltage relationships between the input and output signals with a smaller input frequency of 70 Hz. The smaller frequencies demonstrate the worst case for rectification purposes since the capacitor has more time to lose its charge. Again, the green line is the rectified output, and the red line is the simulated microphone input signal.

Microphone Sensitivity and Power Noise

After receiving our parts in, the first thing we did was connect a microphone to a simple circuit with an oscilloscope to get an idea of the signal we would have to work with. In doing so, we ran into two problems: microphone sensitivity and power noise.

The microphone was relatively insensitive to sound sources greater than 6-12 inches away. In order to obtain a signal much greater than the best case noise levels, we would have to place our sound source (in this case a computer speaker driving a single frequency) inches from the microphone.

The second problem concerning power noise occurred when we connected an oscillator within the same circuit using the same power supply. This introduced a large amount of noise into the signal from the microphone that leaves the microphone signal almost unreadable.

Future Design/Implementation Issues

Concerning the microphone sensitivity, we decided to purchase a different microphone for comparison. We chose an omnidirectional electret condenser microphone from RadioShack (270-090). With this microphone, we received slightly better sensitivity; however, the trade-off would be directionality.

Concerning the noise caused by the oscillator, we plan to study the noise more thoroughly and see if we cannot eliminate it with a filter. Also, upon the successful implementation of the dual switched capacitor, we will test for a cleaner signal.

PCB Generation

We have decided on the PureSoft's EAGLE 4.0 (<http://www.puresoft.co.uk/eagle/>) printed circuit board design software. This software appears to be easy to use. Powerful, and allows for a free trial version to download. We have already generated the pcb for the microphone array board. However, we are still working out the final details of the circuit's layout on the board. Once this is accomplished, we will use the resources Prof. Gutierrez-Osuna has provided us to get it built.

Schedule/Order Status

As far as our initial scheduling goes, we are right on time with our initial proposed work schedule (Figure 8). We have already ordered the robot, the microphones needed for our microphone array, some sample IC's, the sound dampening foam, and other parts need for construction. The only parts we have yet to order are just resistors and capacitors needed for our filter and construction of the signal rectifier. We will get these parts either from the EE Lab on campus or purchase them at Radio Shack. Figure 9 shows our working parts list of what we have ordered and what we plan to get.

Future Plans

The signals we have observed from the microphone have been on the order of millivolts and thus will need to be amplified. We have since ordered samples of single powered operational amplifiers for this purpose. Our robot kit should be in shortly and we will begin construction of the robot. This will take some time because our robot is not assembled. While that is going on, we hope to have everything necessary for our circuit design. Time is moving fast and we must have a completed design soon to send to be constructed.

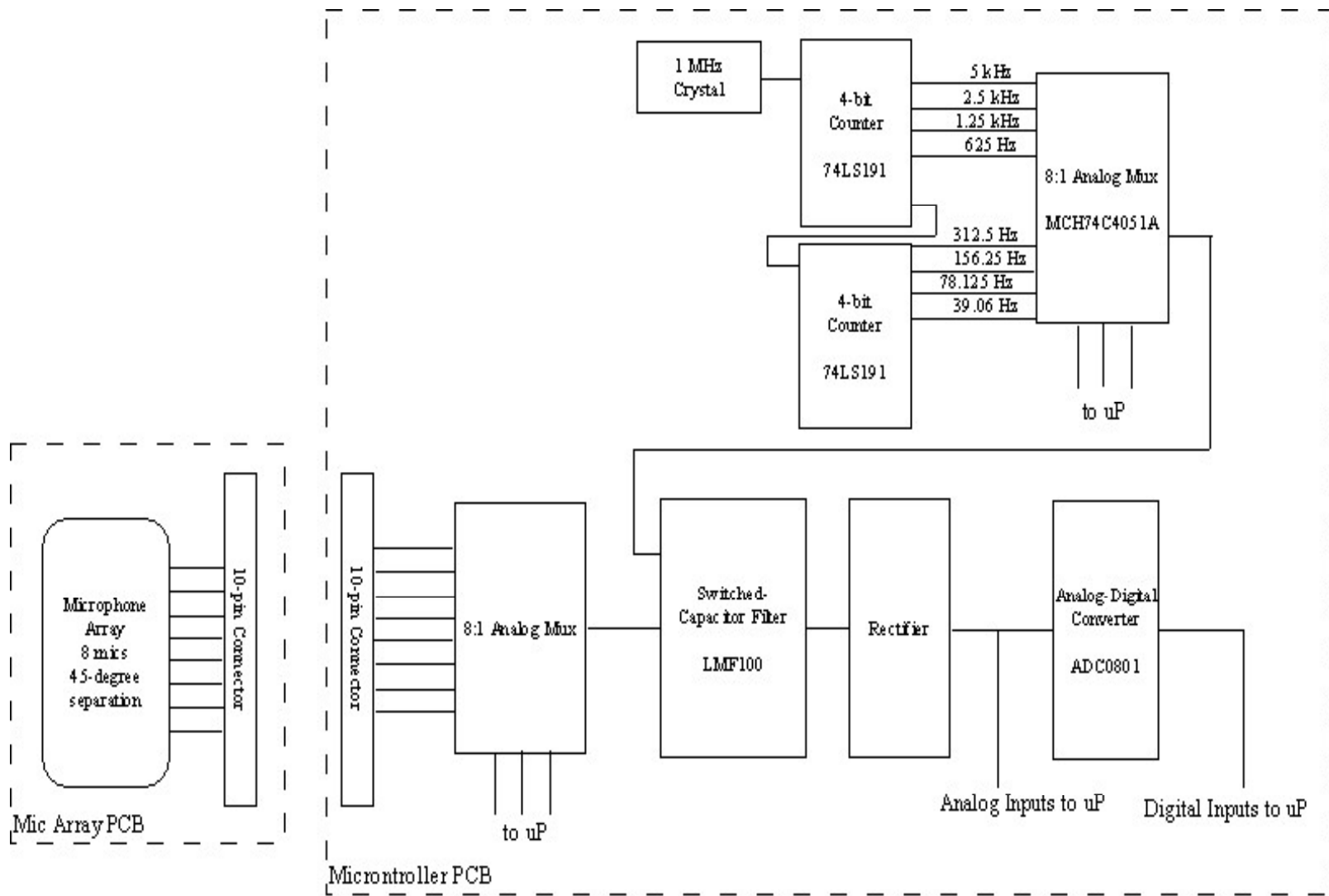

Figure 1 – Current Design Diagram

LMF100

High Performance Dual Switched Capacitor Filter

General Description

The LMF100 consists of two independent general purpose high performance switched capacitor filters. With an external clock and 2 to 4 resistors, various second-order and first-order filtering functions can be realized by each filter block. Each block has 3 outputs. One output can be configured to perform either an allpass, highpass, or notch function. The other two outputs perform bandpass and lowpass functions. The center frequency of each filter stage is tuned by using an external clock or a combination of a clock and resistor ratio. Up to a 4th-order biquadratic function can be realized with a single LMF100. Higher order filters are implemented by simply cascading additional packages, and all the classical filters (such as Butterworth, Bessel, Elliptic, and Chebyshev) can be realized.

The LMF100 is fabricated on National Semiconductor's high performance analog silicon gate CMOS process,

LMCMOS™. This allows for the production of a very low offset, high frequency filter building block. The LMF100 is pin-compatible with the industry standard MF10, but provides greatly improved performance.

Features

- Wide 4V to 15V power supply range
- Operation up to 100 kHz
- Low offset voltage: typically
(50:1 or 100:1 mode): Vos1 = ±5 mV
Vos2 = ±15 mV
Vos3 = ±15 mV
- Low crosstalk -60 dB
- Clock to center frequency ratio accuracy ±0.2% typical
- $f_0 \times Q$ range up to 1.8 MHz
- Pin-compatible with MF10

4th Order 100 kHz Butterworth Lowpass Filter

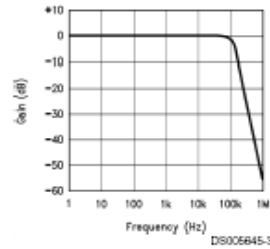
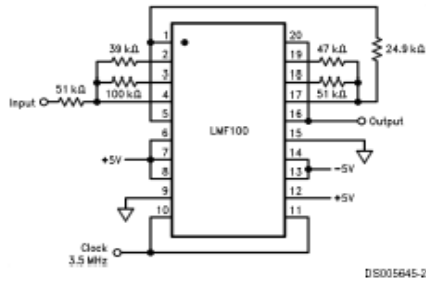

Connection Diagram

Surface Mount and Dual-In-Line Package

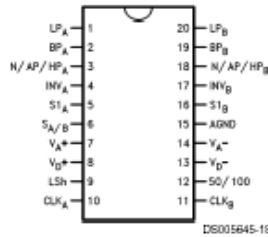

Top View
Order Number
LMF100CCN or LMF100CIWM
See NS Package Number N20A or M20B

LMCMOS™ is a trademark of National Semiconductor Corporation.

Figure 2 – Switched Capacitor Filter

**Bode Plot of Ideal Transfer Function
of National Semiconductor LMF100
High Performance Dual Switched Capacitor Filter
Q = 3**

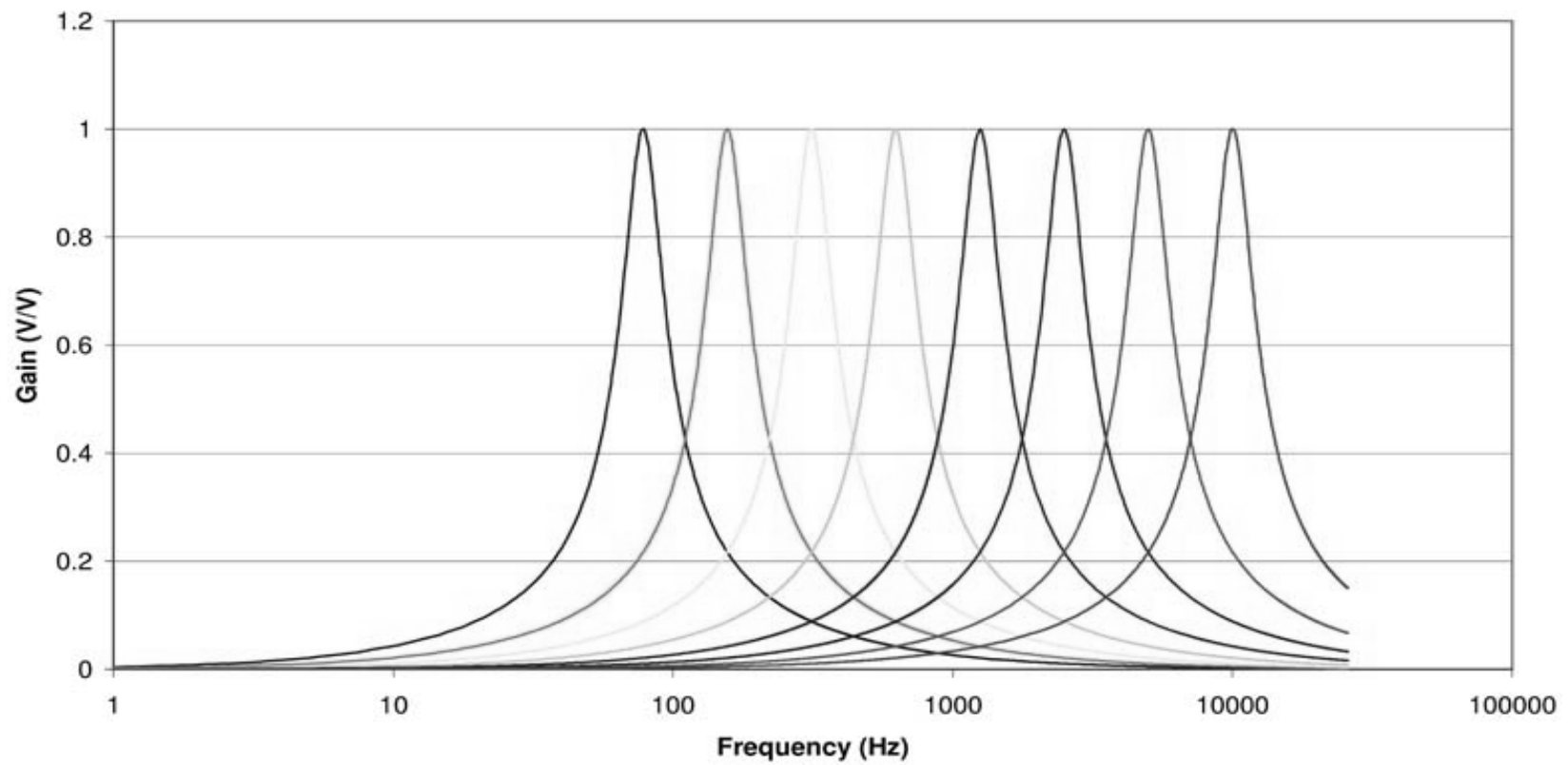

Figure 3



Figure 4 – Mark III Robot

Half Wave Rectifier

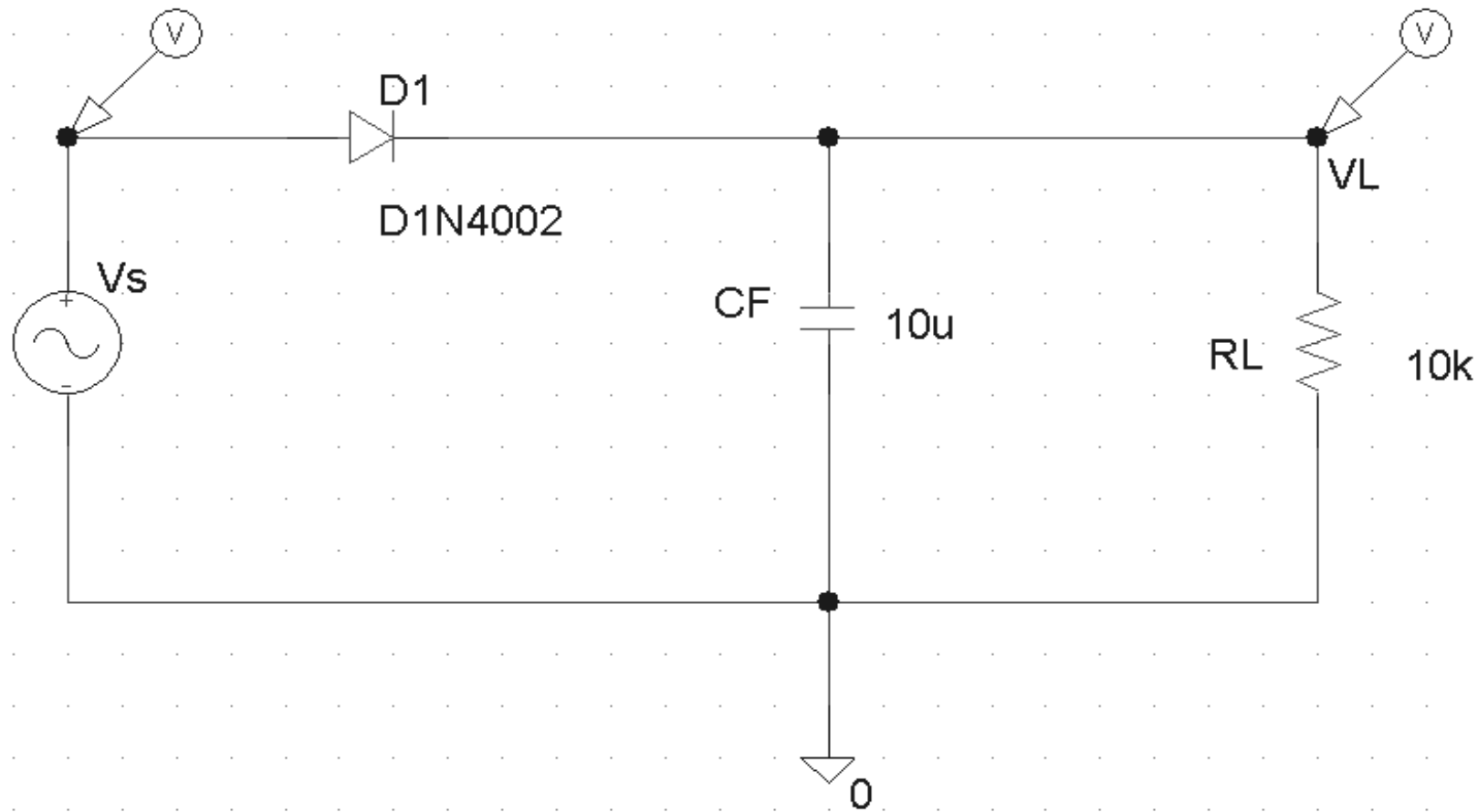

Figure 5

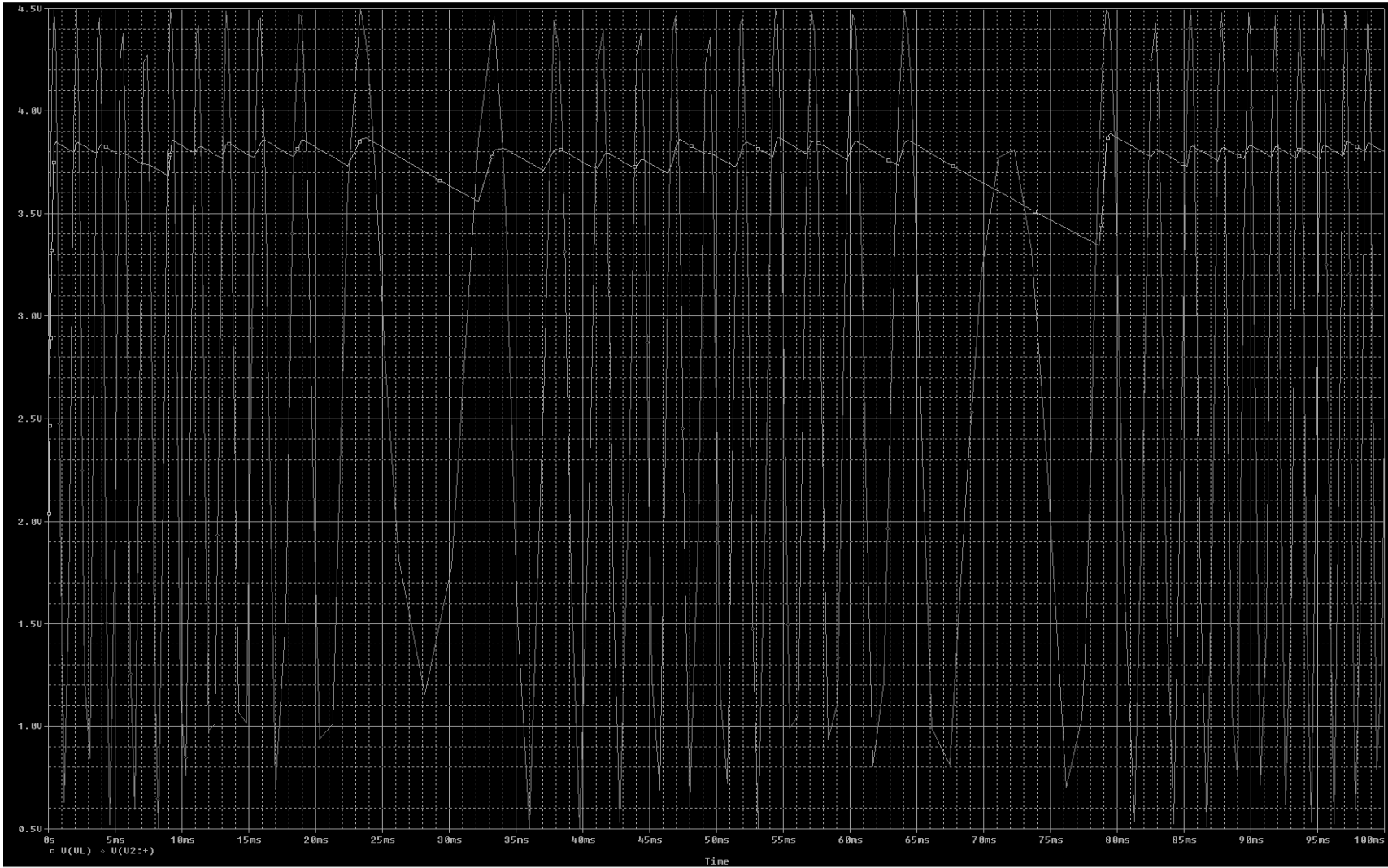

Figure 6 - Voltage relationships between the input and output signals with a constant 4V signal at 400 Hz

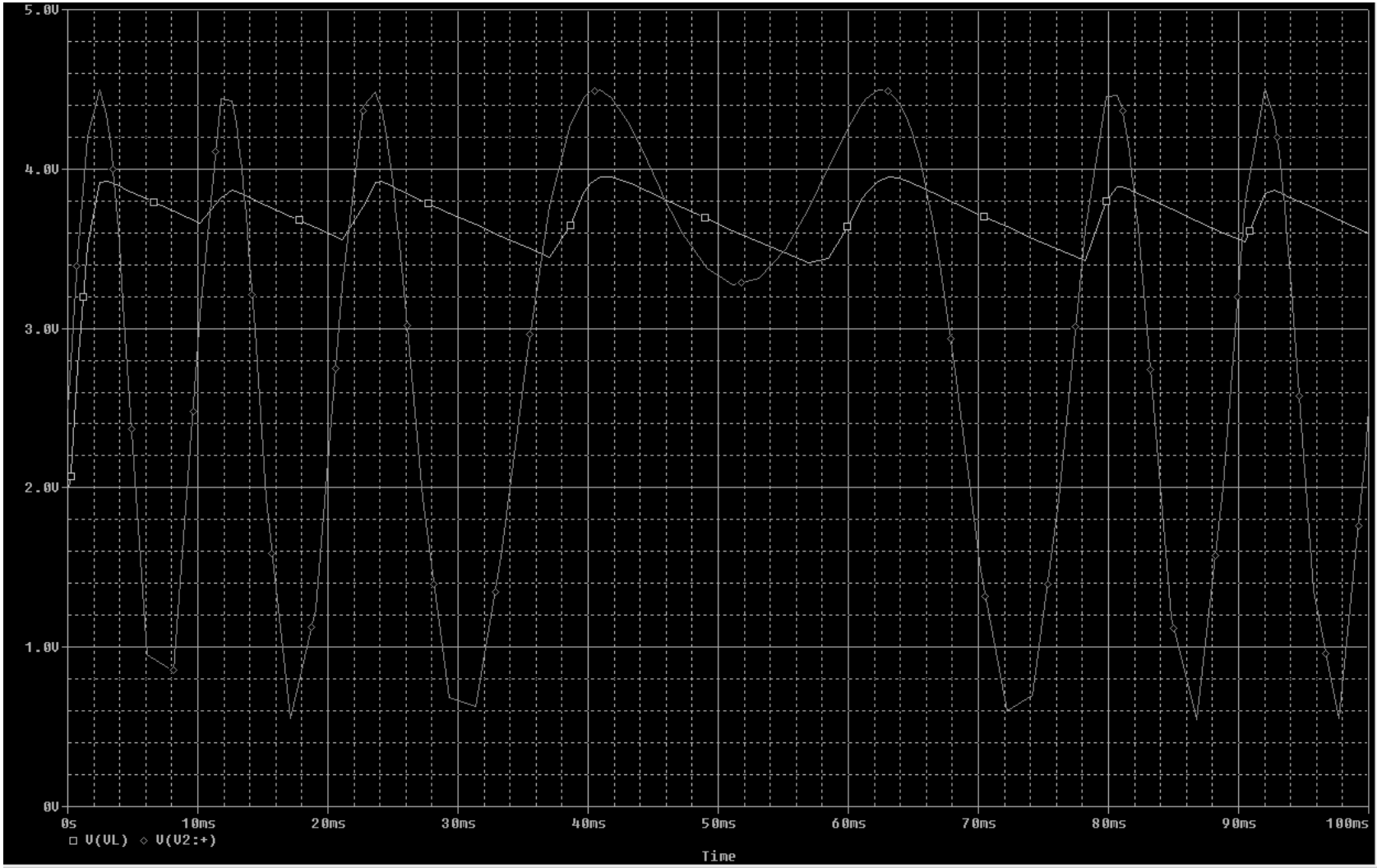

Figure 7 - Voltage relationships between the input and output signals with a constant 4V signal at 70 Hz

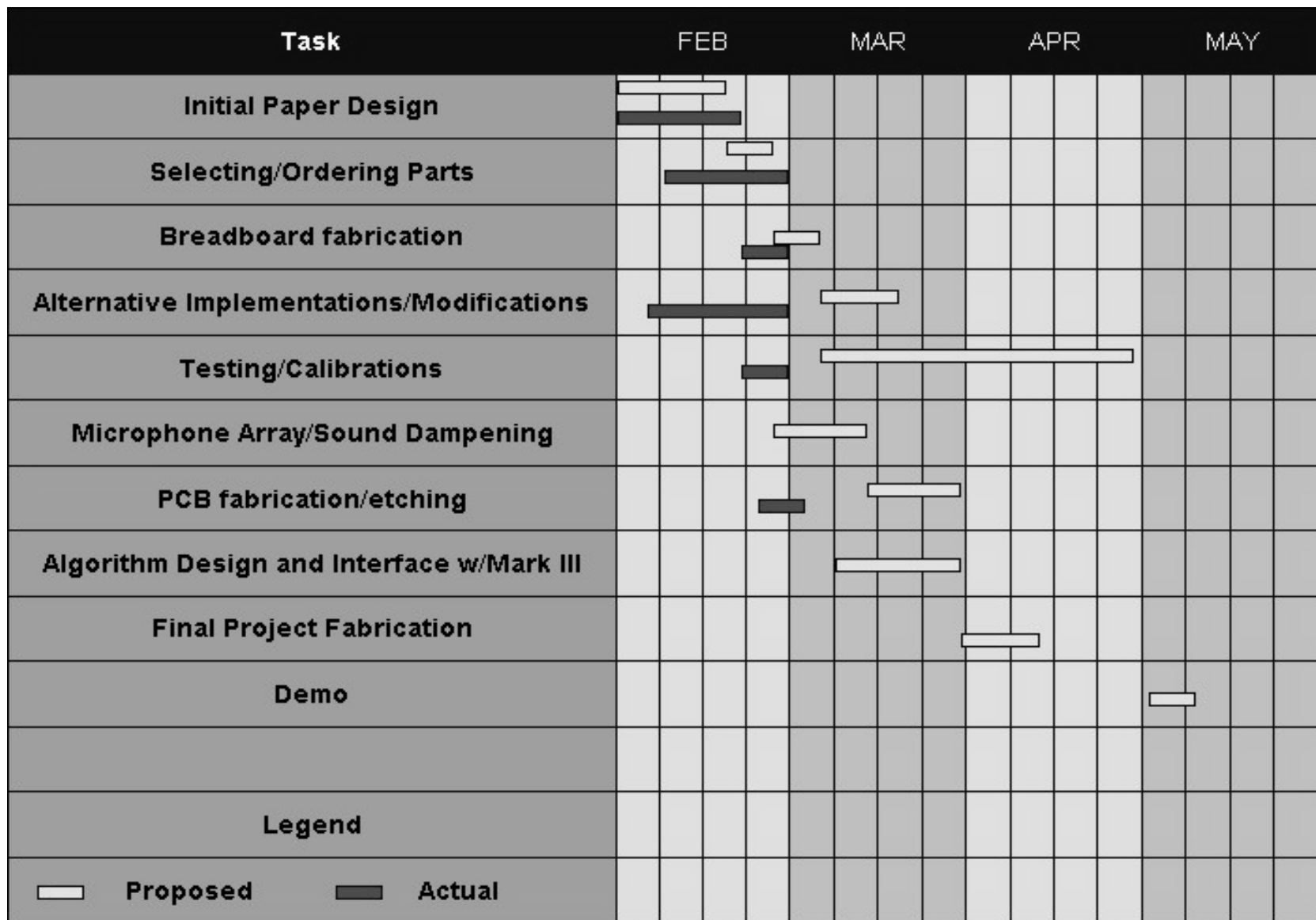

Figure 8 – Updated Gantt Chart

Nomenclature	Part Number	Contact	Quantity	Price	Total
Electret Microphone - Panasonic	WM-65A103	www.digikey.com Navigate to online ordering and enter quantity and part number Telephone: 800-344-4539	16	1.82	29.31
8:1 Analog Mux	MC74LVX4051D	www.onsemi.com (Ordered already)	5	Free samples	0.00
2:1 Analog Mux	NLAS1053US	www.onsemi.com (Ordered already)	5	Free samples	0.00
Dynamat Sound Dampening Sheet - <u>Dynamat</u> <u>Original</u> Speaker Kit	10115	www.dynamat.com (Follow online store link and look for part number)	1	15.00	15.00
Analog- Digital Converter	ADC0801	www.national.com (Ordered already)	5	Free samples	0.00
Switched Filter	LMF100	www.national.com	5	Free samples	0.00
Mark 3 (OOPEC)		Junun.org		98.00	98.00
OOPEC 2+ upgrade		Junun.org		30.00	30.00
Diode	D1N4002		16		
Capacitor	1uF		5		
Resistors	20kOhm		5		

Figure 9 – Working Parts List