

### TGS 2620 - for the detection of Solvent Vapors

#### Features:

- \* Low power consumption
- \* High sensitivity to alcohol and organic solvent vapors
- \* Long life and low cost
- \* Uses simple electrical circuit

The sensing element is comprised of a metal oxide semiconductor layer formed on an alumina substrate of a sensing chip together with an integrated heater. In the presence of a detectable gas, the sensor's conductivity increases depending on the gas concentration in the air. A simple electrical circuit can convert the change in conductivity to an output signal which corresponds to the gas concentration.

The **TGS 2620** has high sensitivity to the vapors of organic solvents as well as other volatile vapors. It also has sensitivity to a variety of combustible gases such as carbon monoxide, making it a good general purpose sensor.

Due to miniaturization of the sensing chip, TGS 2620 requires a heater current of only 42mA and the device is housed in a standard TO-5 package.

The figure below represents typical sensitivity characteristics, all data having been gathered at standard test conditions (see reverse side of this sheet). The Y-axis is indicated as *sensor resistance ratio* ( $R_s/R_o$ ) which is defined as follows:

- $R_s$  = Sensor resistance in displayed gases at various concentrations
- $R_o$  = Sensor resistance in 300ppm of ethanol

#### Sensitivity Characteristics:

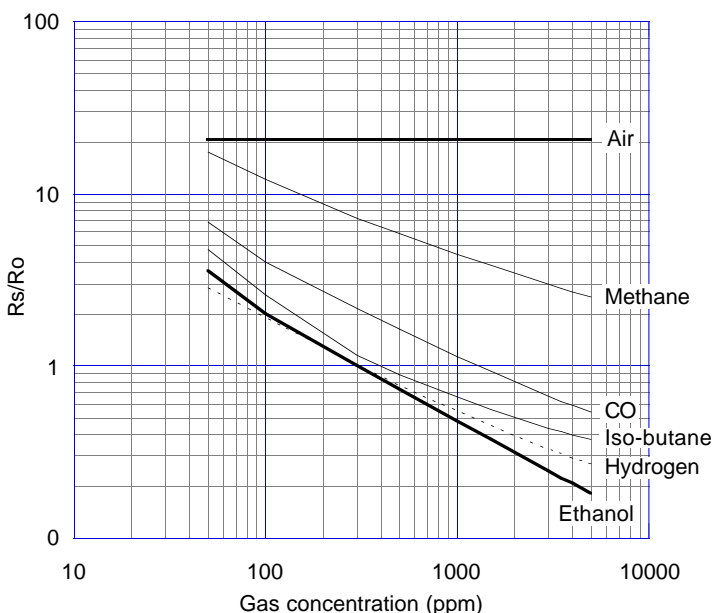

#### Applications:

- \* Alcohol testers
- \* Organic vapor detectors/alarms
- \* Solvent detectors for factories, dry cleaners, and semiconductor industries

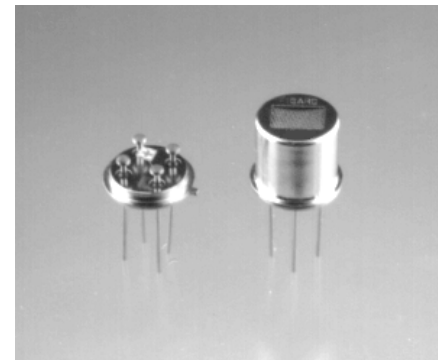

The figure below represents typical temperature and humidity dependency characteristics. Again, the Y-axis is indicated as *sensor resistance ratio* ( $R_s/R_o$ ), defined as follows:

- $R_s$  = Sensor resistance in 300ppm of ethanol at various temperatures/humidities
- $R_o$  = Sensor resistance in 300ppm of ethanol at 20°C and 65% R.H.

#### Temperature/Humidity Dependency:

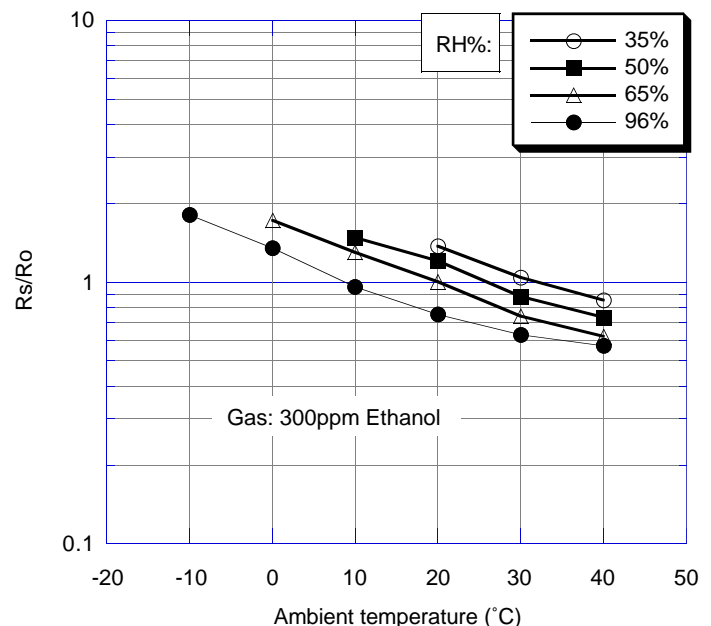

**IMPORTANT NOTE:** OPERATING CONDITIONS IN WHICH FIGARO SENSORS ARE USED WILL VARY WITH EACH CUSTOMER'S SPECIFIC APPLICATIONS. FIGARO STRONGLY RECOMMENDS CONSULTING OUR TECHNICAL STAFF BEFORE DEPLOYING FIGARO SENSORS IN YOUR APPLICATION AND, IN PARTICULAR, WHEN CUSTOMER'S TARGET GASES ARE NOT LISTED HEREIN. FIGARO CANNOT ASSUME ANY RESPONSIBILITY FOR ANY USE OF ITS SENSORS IN A PRODUCT OR APPLICATION FOR WHICH SENSOR HAS NOT BEEN SPECIFICALLY TESTED BY FIGARO.

**Basic Measuring Circuit:**

The sensor requires two voltage inputs: heater voltage (V<sub>H</sub>) and circuit voltage (V<sub>C</sub>). The heater voltage (V<sub>H</sub>) is applied to the integrated heater in order to maintain the sensing element at a specific temperature which is optimal for sensing. Circuit voltage (V<sub>C</sub>) is applied to allow measurement of voltage (V<sub>RL</sub>) across a load resistor (R<sub>L</sub>) which is connected in series with the sensor.

A common power supply circuit can be used for both V<sub>C</sub> and V<sub>H</sub> to fulfill the sensor's electrical requirements. The value of the load resistor (R<sub>L</sub>) should be chosen to optimize the alarm threshold value, keeping power consumption (P<sub>S</sub>) of the semiconductor below a limit of 15mW. Power consumption (P<sub>S</sub>) will be highest when the value of R<sub>S</sub> is equal to R<sub>L</sub> on exposure to gas.

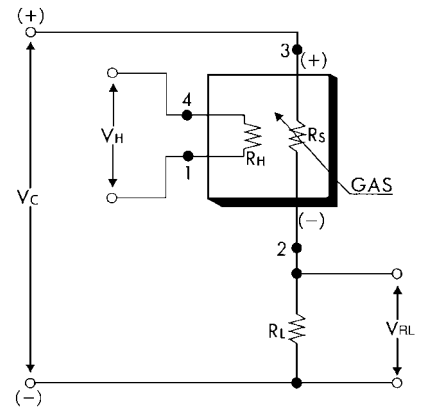

**Specifications:**

Model number		TGS 2620	
Sensing element type		D1	
Standard package		TO-5 metal can	
Target gases		Alcohol, Solvent vapors	
Typical detection range		50 ~ 5,000 ppm	
Standard circuit conditions	Heater Voltage	V <sub>H</sub>	5.0±0.2V DC/AC
	Circuit voltage	V <sub>C</sub>	5.0±0.2V DC    P <sub>S</sub> ≤ 15mW
	Load resistance	R <sub>L</sub>	Variable    P <sub>S</sub> ≤ 15mW
Electrical characteristics under standard test conditions	Heater resistance	R <sub>H</sub>	83Ω at room temp. (typical)
	Heater current	I <sub>H</sub>	42 ± 4mA
	Heater power consumption	P <sub>H</sub>	approx. 210mW
	Sensor resistance	R <sub>S</sub>	1 ~ 5 kΩ in 300ppm ethanol
	Sensitivity (change ratio of R <sub>S</sub> )		0.3 ~ 0.5 $\frac{R_S(300ppm)}{R_S(50ppm)}$
Standard test conditions	Test gas conditions	Ethanol vapor in air at 20±2°C, 65±5%RH	
	Circuit conditions	V <sub>C</sub> = 5.0±0.01V DC V <sub>H</sub> = 5.0±0.05V DC	
	Conditioning period before test	7 days	

The value of power dissipation (P<sub>S</sub>) can be calculated by utilizing the following formula:

$$P_S = \frac{(V_C - V_{RL})^2}{R_S}$$

Sensor resistance (R<sub>S</sub>) is calculated with a measured value of V<sub>RL</sub> by using the following formula:

$$R_S = \frac{V_C - V_{RL}}{V_{RL}} \times R_L$$

**Structure and Dimensions:**

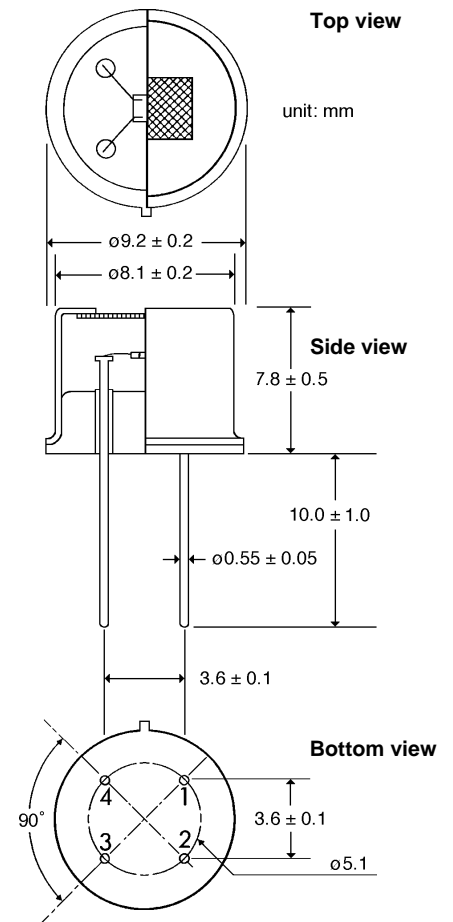

**Pin connection:**

- 1 : Heater
- 2 : Sensor electrode (-)
- 3 : Sensor electrode (+)
- 4 : Heater

**FIGARO USA, INC.**

3703 West Lake Ave. Suite 203  
 Glenview, Illinois 60025  
 Phone: (847)-832-1701  
 Fax: (847)-832-1705  
 email: figarousa@figarosensor.com