

# Deep Learning Overview

- Spring 2017
- Yoonsuck Choe

1

## Brief Intro to Neural Networks

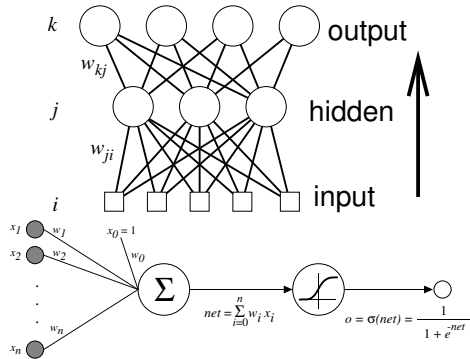

Deep learning is based on neural networks.

- Weighted sum followed by nonlinear activation function.
- Weights adjusted using *gradient descent* ( $\eta$  = learning rate):

$$w_{ij} \leftarrow w_{ij} + \eta \frac{\partial E}{\partial w_{ij}}$$

3

# What Is Deep Learning?

- Learning higher level abstractions/representations from data.
- Motivation: how the brain represents and processes sensory information in a hierarchical manner.

- The ventral (recognition) pathway in the visual cortex has multiple stages
- Retina - LGN - V1 - V2 - V4 - PIT - AIT ...

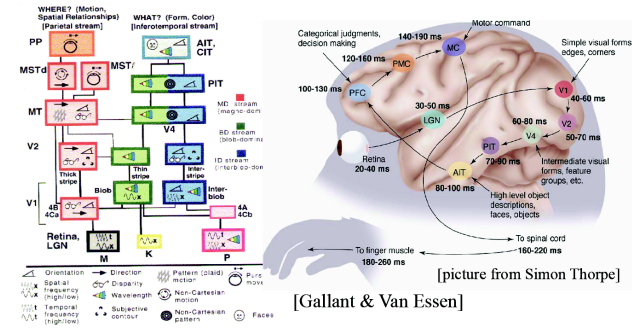

From LeCun's Deep Learning Tutorial

2

## Intro to Neural Network: Backpropagation

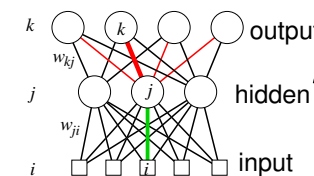

Weight  $w_{ji}$  is updated as:  $w_{ji} \leftarrow w_{ji} + \eta \delta_j a_i$ , where

- $a_i$  : activity at input side of weight  $w_{ji}$ .
- Hidden to output weights (thick red weight).  $T_k$  is target value.

$$\delta_k = (T_k - a_k) \sigma'(net_k)$$

- Deeper weights (green line in figure above).

$$\delta_j = \left[ \sum_k w_{kj} \delta_k \right] \sigma'(net_j)$$

## Deep Learning

- Complex models with large number of parameters
  - Hierarchical representations
  - More parameters = more accurate on training data
  - Simple learning rule for training (gradient-based).
- Lots of data
  - Needed to get better generalization performance.
  - High-dimensional input need exponentially many inputs (curse of dimensionality).
- Lots of computing power: GPGPU, etc.
  - Training large networks can be time consuming.

5

## The Rise of Deep Learning

Made popular in recent years

- Geoffrey Hinton et al. (2006).
- Andrew Ng & Jeff Dean (Google Brain team, 2012).
- Schmidhuber et al.'s deep neural networks (won many competitions and in some cases showed super human performance; 2011–). Recurrent neural networks using LSTM (Long Short-Term Memory).
- Google Deep Mind: Atari 2600 games (2015), AlphaGo (2016).
- ICLR, International Conference on Learning Representations: First meeting in 2013.
- First deep learning textbook (Goodfellow, Bengio, Courville, 2016).

7

## Deep Learning, in the Context of AI/ML

Deep Learning:  
Automating  
Feature Discovery

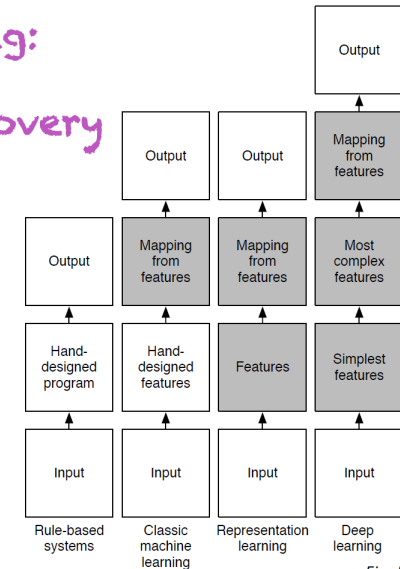

Fig: 1. Goodfellow

6

From LeCun's Deep Learning Tutorial

## Long History (in Hind Sight)

- Fukushima's Neocognitron (1980).
- LeCun et al.'s Convolutional neural networks (1989).
- Schmidhuber's work on stacked recurrent neural networks (1993). Vanishing gradient problem.
- See Schmidhuber's extended review: Schmidhuber, J. (2015). Deep learning in neural networks: An overview. *Neural Networks*, 61, 85-117.

8

## History: Fukushima's Neocognitron

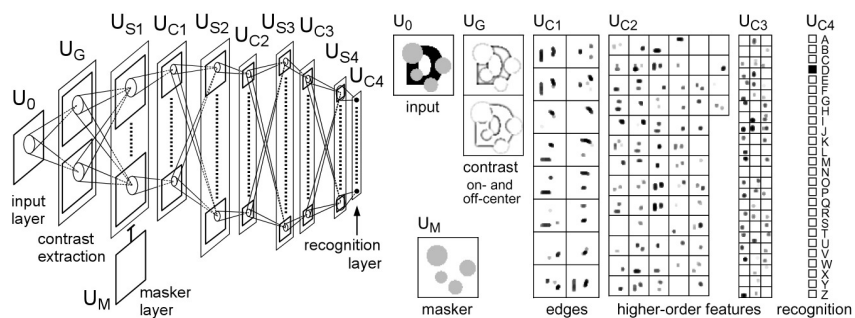

- Appeared in journal *Biological Cybernetics* (1980).
- Multiple layers with local receptive fields.
- S cells (trainable) and C cells (fixed weight).
- Deformation-resistant recognition.

9

## History: LeCun's Convolutional Neural Nets

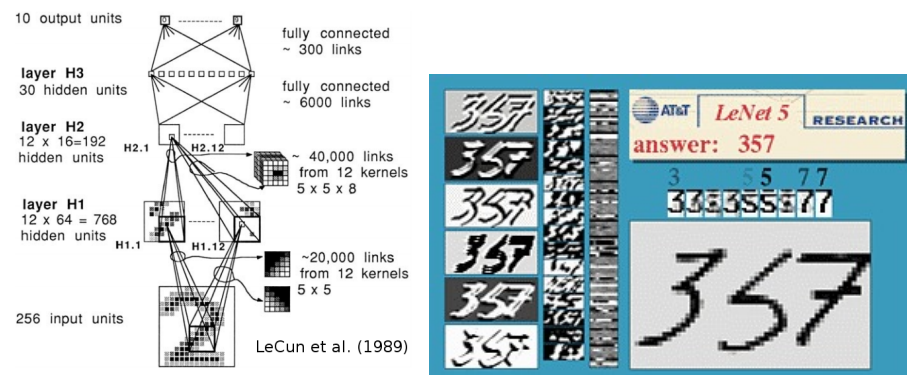

- Convolution kernel (weight sharing) + Subsampling
- Fully connected layers near the end.
- Became a main-stream method in deep learning.

10

## Motivating Deep Learning: Tensorflow Demo

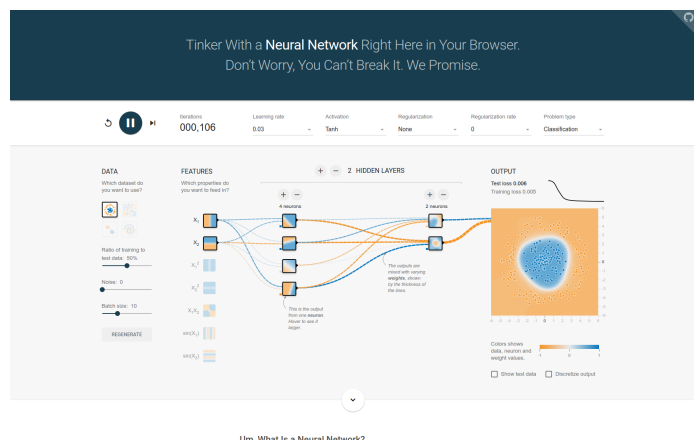

- <http://playground.tensorflow.org>
- Demo to explore why deep nnet is powerful and how it is limited.

11

## Current Trends

- Deep belief networks (based on Boltzmann machine)
- Convolutional neural networks
- Deep Q-learning Network (extensions to reinforcement learning)
- Deep recurrent neural networks using (LSTM)
- Applications to diverse domains.
  - Vision, speech, video, NLP, etc.
- Lots of open source tools available.

12

## Boltzmann Machine to Deep Belief Nets

- Haykin Chapter 11: Stochastic Methods rooted in statistical mechanics.

13

## Boltzmann Machine: Energy

- Network state:  $\mathbf{x}$  from random variable  $\mathbf{X}$ .
- $w_{ij} = w_{ji}$  and  $w_{ii} = 0$ .
- Energy (in analogy to thermodynamics):

$$E(\mathbf{x}) = -\frac{1}{2} \sum_i \sum_{j, i \neq j} w_{ji} x_i x_j$$

15

## Boltzmann Machine

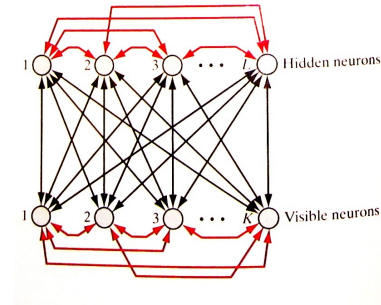

- Stochastic binary machine: +1 or -1.
- Fully connected symmetric connections:  $w_{ij} = w_{ji}$ .
- Visible vs. hidden neurons, clamped vs. free-running.
- Goal: Learn weights to model prob. dist of visible units.
- Unsupervised. Pattern completion.

14

## Boltzmann Machine: Prob. of a State $\mathbf{x}$

- Probability of a state  $\mathbf{x}$  given  $E(\mathbf{x})$  follows the *Gibbs distribution*:

$$P(\mathbf{X} = \mathbf{x}) = \frac{1}{Z} \exp\left(-\frac{E(\mathbf{x})}{T}\right),$$

- $Z$ : *partition function* (normalization factor – hard to compute)

$$Z = \sum_{\forall \mathbf{x}} \exp(-E(\mathbf{x})/T)$$

- $T$ : temperature parameter.
- Low energy states are exponentially more probable.
- State  $\mathbf{x}$  changed over time following the probability distribution  $P(\mathbf{X} = \mathbf{x})$ .

16

## Boltzmann Learning Rule

- Learning based on correlation  $\rho_{ji}^+$  (clamped) and  $\rho_{ji}^-$  (free-running).

$$\Delta w_{ji} = \eta \frac{\partial L(\mathbf{w})}{\partial w_{ji}} = \eta (\rho_{ji}^+ - \rho_{ji}^-)$$

where  $L(\mathbf{w})$  is the log likelihood of the pattern being any of the training patterns, and  $\eta$  is the learning rate. This is *gradient ascent*.

17

## Logistic (or Directed) Belief Net

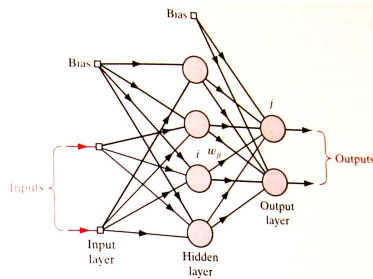

- Similar to Boltzmann Machine, but with directed, acyclic connections.

$$P(X_j = x_j | X_1 = x_1, \dots, X_{j-1} = x_{j-1}) = P(X_j = x_j | \text{parents}(X_j))$$

- Same learning rule:

$$\Delta w_{ji} = \eta \frac{\partial L(\mathbf{w})}{\partial w_{ji}}$$

- With dense connections, calculation of  $P$  becomes intractable.

19

## Boltzmann Machine Summary

- Theoretically elegant.
- Can be very slow.

18

## Deep Belief Net (1)

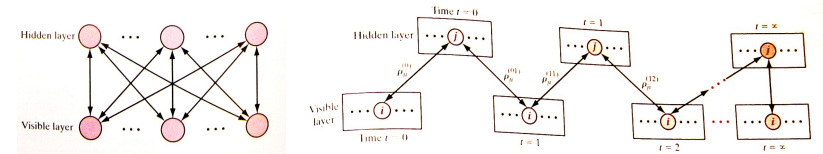

- Overcomes issues with Logistic Belief Net. Hinton et al. (2006)
- Based on Restricted Boltzmann Machine (RBM): visible and hidden layers, with layer-to-layer full connection but no within-layer connections.
- RBM Back-and-forth update: update hidden given visible, then update visible given hidden, etc., then train  $\mathbf{w}$  based on

$$\frac{\partial L(\mathbf{w})}{\partial w_{ji}} = \rho_{ji}^{(0)} - \rho_{ji}^{(\infty)}$$

20

## Deep Belief Net (2)

Deep Belief Net = Layer-by-layer training using RBM.

Hybrid architecture: Top layer = undirected, lower layers directed.

1. Train RBM based on input to form hidden representation.
2. Use hidden representation as input to train another RBM.
3. Repeat steps 2-3.

\* Similar approach: Stacked denoising autoencoders.

Applications: NIST digit recognition, etc.

21

## Deep Convolutional Neural Networks (1)

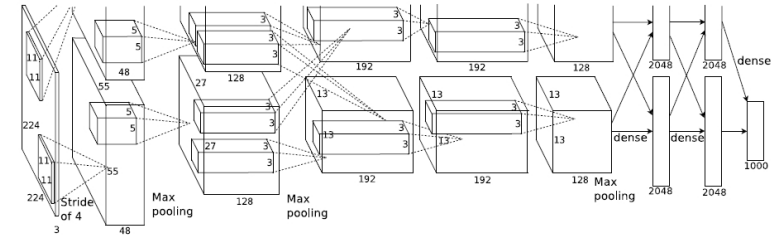

- Krizhevsky et al. (2012)
- Applied to ImageNet competition (1.2 million images, 1,000 classes).
- Network: 60 million parameters and 650,000 neurons.
- Top-1 and top-5 error rates of 37.5% and 17.0%.
- Trained with backprop.

22

## Deep Convolutional Neural Networks (2)



- Learned kernels (first convolutional layer).
- Resembles mammalian RFs: oriented Gabor patterns, color opponency (red-green, blue-yellow).

23

## Deep Convolutional Neural Networks (3)

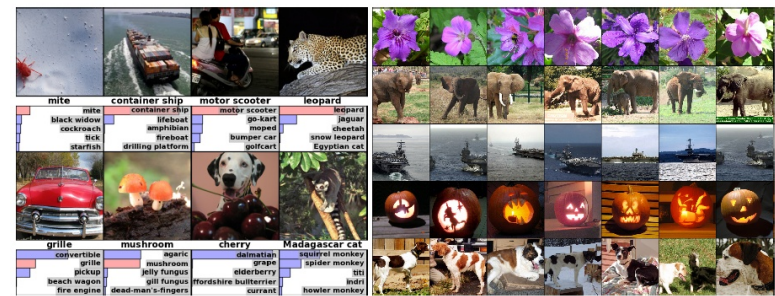

- Left: text on top = correct label. 5 ranked labels: model's estimation.
- Right: Test (1st column) vs. training images with closest hidden representation to the test data.

24



## Deep Q-Network (DQN)

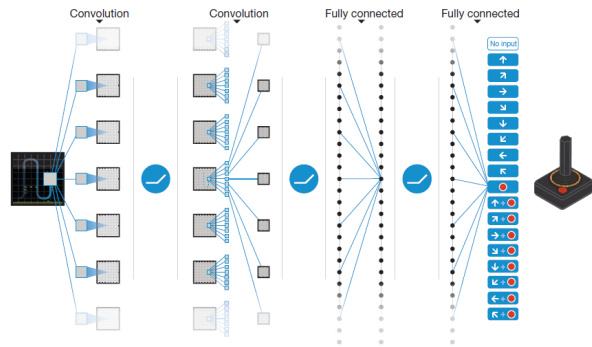

Google Deep Mind (Mnih et al. *Nature* 2015).

- Latest application of deep learning to a *reinforcement learning* domain ( $Q$  as in  $Q$ -learning).
- Applied to *Atari 2600* video game playing.

25

## DQN Overview

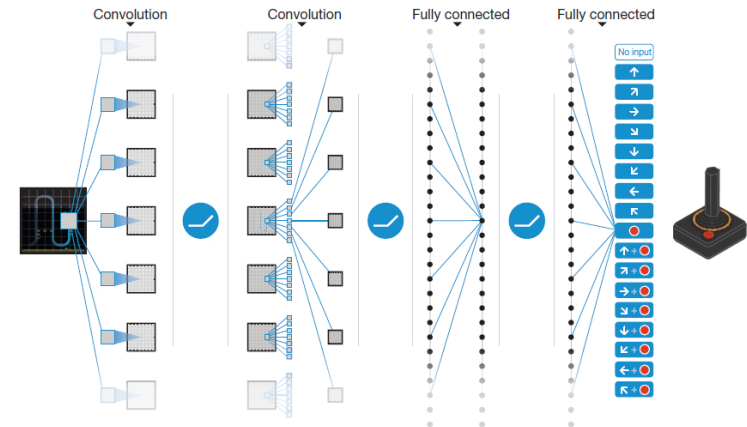

- Input: video screen; Output:  $Q(s, a)$ ; Reward: game score.
- $Q(s, a)$ : action-value function
  - Value of taking action  $a$  when in state  $s$ .

26

## DQN Overview

- Input preprocessing
- Experience replay (collect and replay state, action, reward, and resulting state)
- Delayed (periodic) update of  $Q$ .
- Moving target  $\hat{Q}$  value used to compute error (loss function  $L$ , parameterized by weights  $\theta_i$ ).

- Gradient descent:

$$\frac{\partial L}{\partial \theta_i}$$

27

## DQN Algorithm

**Algorithm 1:** deep Q-learning with experience replay.

Initialize replay memory  $D$  to capacity  $N$

Initialize action-value function  $Q$  with random weights  $\theta$

Initialize target action-value function  $\hat{Q}$  with weights  $\theta^- = \theta$

For episode = 1,  $M$  do

Initialize sequence  $s_1 = \{x_1\}$  and preprocessed sequence  $\phi_1 = \phi(s_1)$

For  $t = 1, T$  do

With probability  $\epsilon$  select a random action  $a_t$

otherwise select  $a_t = \operatorname{argmax}_a Q(\phi(s_t), a; \theta)$

Execute action  $a_t$  in emulator and observe reward  $r_t$  and image  $x_{t+1}$

Set  $s_{t+1} = s_t, a_t, x_{t+1}$  and preprocess  $\phi_{t+1} = \phi(s_{t+1})$

Store transition  $(\phi_t, a_t, r_t, \phi_{t+1})$  in  $D$

Sample random minibatch of transitions  $(\phi_j, a_j, r_j, \phi_{j+1})$  from  $D$

Set  $y_j = \begin{cases} r_j & \text{if episode terminates at step } j+1 \\ r_j + \gamma \max_{a'} \hat{Q}(\phi_{j+1}, a'; \theta^-) & \text{otherwise} \end{cases}$

Perform a gradient descent step on  $(y_j - Q(\phi_j, a_j; \theta))^2$  with respect to the network parameters  $\theta$

Every  $C$  steps reset  $\hat{Q} = Q$

End For

End For

28

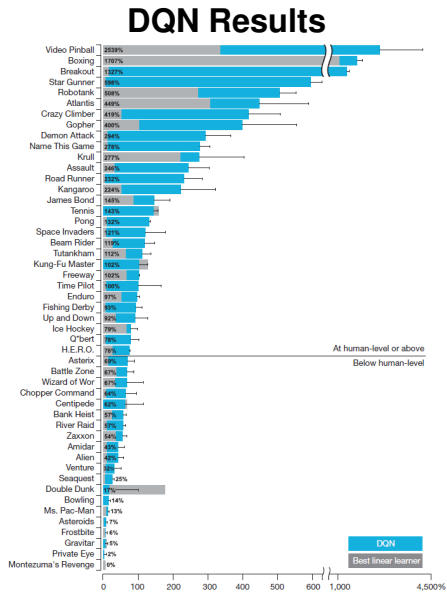

- Superhuman performance on over half of the games.

29

### DQN Hidden Layer Representation (t-SNE map)

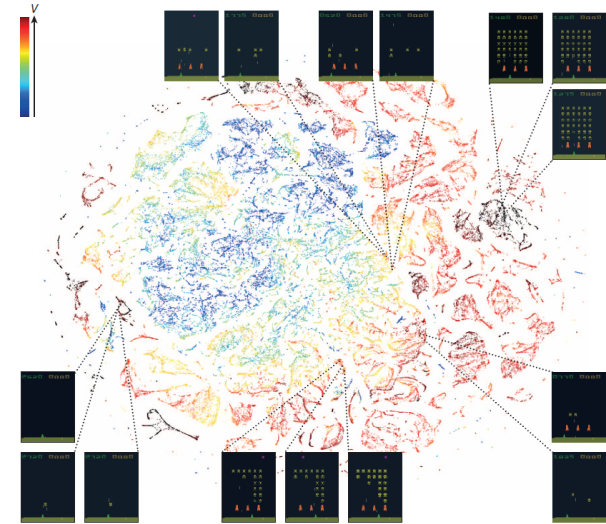

- Similar perception, similar reward clustered.

30

### DQN Operation

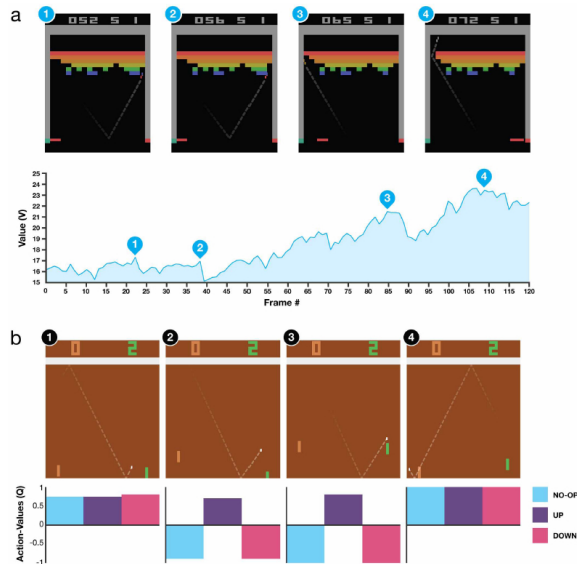

- Value vs. game state; Game state vs. action value.

### Deep Recurrent Neural Networks

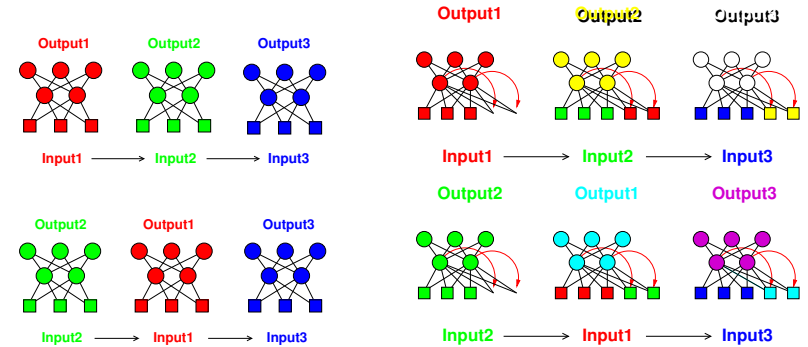

#### Feedforward

#### Recurrent

- Feedforward: No memory of past input.
- Recurrent:
  - Good: Past input affects present output.
  - Bad: Cannot remember far into the past.

32



## RNN Training: Backprop in Time

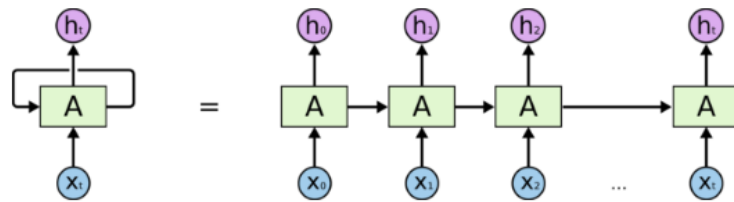

An unrolled recurrent neural network.

- Can unfold recurrent loop: Make it into a feedforward net.
- Use the same backprop algorithm for training.
- Again, cannot remember too far into the past.

Fig from <http://colah.github.io/posts/2015-08-Understanding-LSTMs/>

33

## Long Short-Term Memory

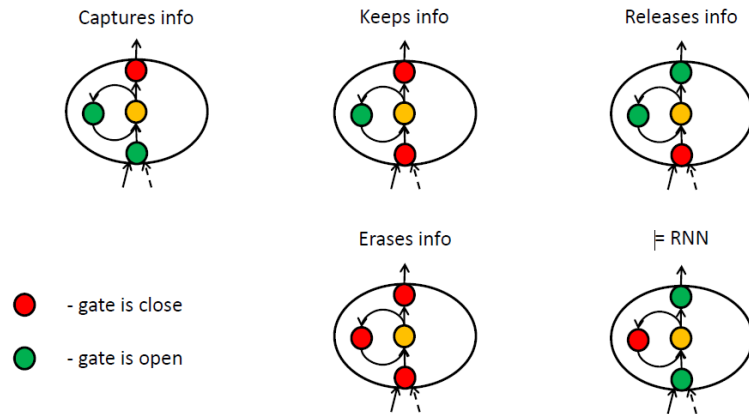

- Long-term retention possible with LSTM.

From [http://www.machinelearning.ru/wiki/images/6/6c/RNN\\_and\\_LSTM\\_16102015.pdf](http://www.machinelearning.ru/wiki/images/6/6c/RNN_and_LSTM_16102015.pdf)

35

## Long Short-Term Memory

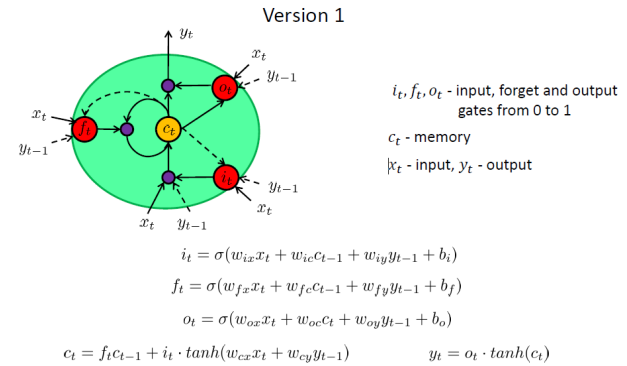

- LSTM to the rescue (Hochreiter and Schmidhuber, 2017).
- Built-in recurrent memory that can be written (Input gate), reset (Forget gate), and outputted (Output gate).

From [http://www.machinelearning.ru/wiki/images/6/6c/RNN\\_and\\_LSTM\\_16102015.pdf](http://www.machinelearning.ru/wiki/images/6/6c/RNN_and_LSTM_16102015.pdf)

34

## Long Short-Term Memory in Action

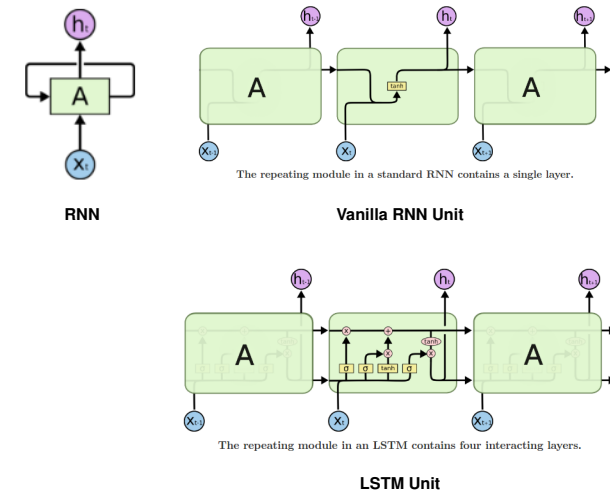

- Unfold in time and use backprop as usual.

Fig from <http://colah.github.io/posts/2015-08-Understanding-LSTMs/>

36

## LSTM Applications

- Sequence classification

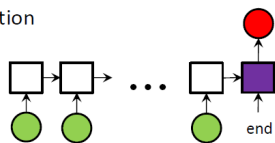

- Sequence translation

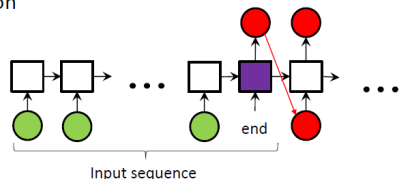

- Applications: Sequence classification, Sequence translation.

From <http://machinelearning.ru>

37

## LSTM Applications

handwriting -> handwriting

Next pen position (we predict parameters):  
 $x_1, x_2$  - mixture of bivariate Gaussians  
 $x_3$  - Bernoulli distribution

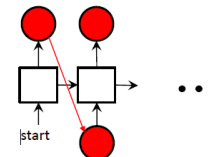

Current pen position:  
 $x_1, x_2$  - pen offset  
 $x_3$  - is it end of the stroke

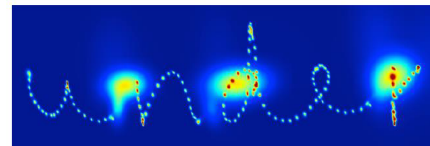

- Applications: Sequence prediction

From <http://machinelearning.ru>

38

## LSTM Applications

text -> handwriting

Next pen position

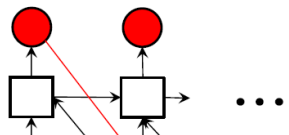

Current pen position

Which letter we write now

text

- Applications: Sequence classification, Sequence prediction, Sequence translation.

From <http://machinelearning.ru>

39

## Deep Learning Applications: Vision

- Give the name of the dominant object in the image
- Top-5 error rates: if correct class is not in top 5, count as error
  - Red: ConvNet, blue: no ConvNet

2012 Teams	%error	2013 Teams	%error	2014 Teams	%error
Supervision (Toronto)	15.3	Clarifai (NYU spinoff)	11.7	GoogLeNet	6.6
ISI (Tokyo)	26.1	NUS (singapore)	12.9	VGG (Oxford)	7.3
VGG (Oxford)	26.9	Zeiler-Fergus (NYU)	13.5	MSRA	8.0
XRCE/INRIA	27.0	A. Howard	13.5	A. Howard	8.1
UvA (Amsterdam)	29.6	OverFeat (NYU)	14.1	DeeperVision	9.5
INRIA/LEAR	33.4	UvA (Amsterdam)	14.2	NUS-BST	9.7
		Adobe	15.2	TTIC-ECP	10.2
		VGG (Oxford)	15.2	XYZ	11.2
		VGG (Oxford)	23.0	UvA	12.1

- ConvNet sweeping image recognition challenges.

From LeCun's Deep Learning Tutorial

40

## Deep Learning Applications: Speech

The dramatic impact of Deep Learning on Speech Recognition (according to Microsoft)

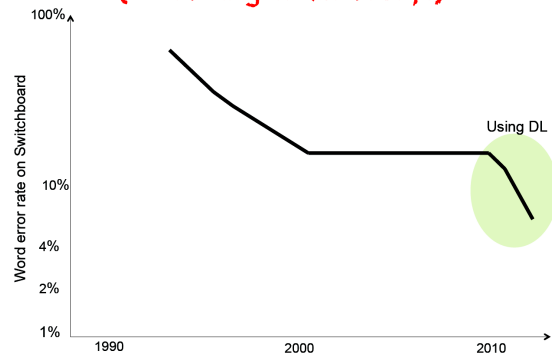

- Deep learning led to major improvement in speech recognition.

From LeCun's Deep Learning Tutorial

41

## Deep Learning Applications: Speech

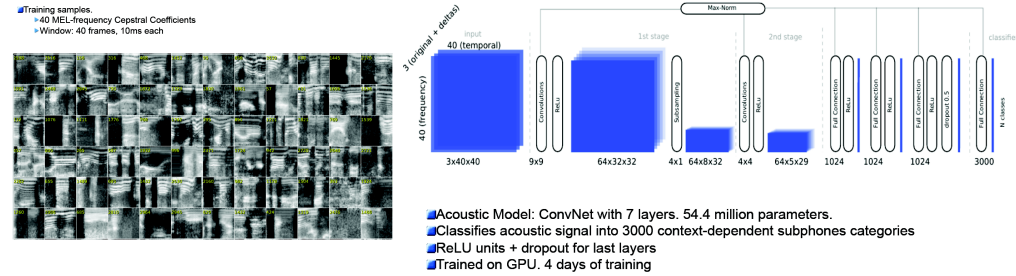

- ConvNet applied to speech recognition.
- Use spectrogram and treat it like a 2D image.

From LeCun's Deep Learning Tutorial

42

## Deep Learning Applications: NLP

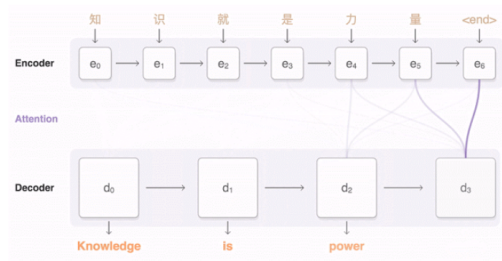
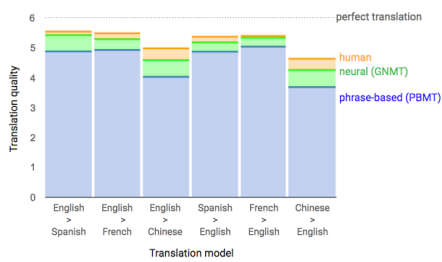

- Based on encoding/decoding and attention.

From <https://research.googleblog.com/2016/09/a-neural-network-for-machine.html>

[//research.googleblog.com/2016/09/a-neural-network-for-machine.html](https://research.googleblog.com/2016/09/a-neural-network-for-machine.html)

43

## Deep Learning Applications: NLP

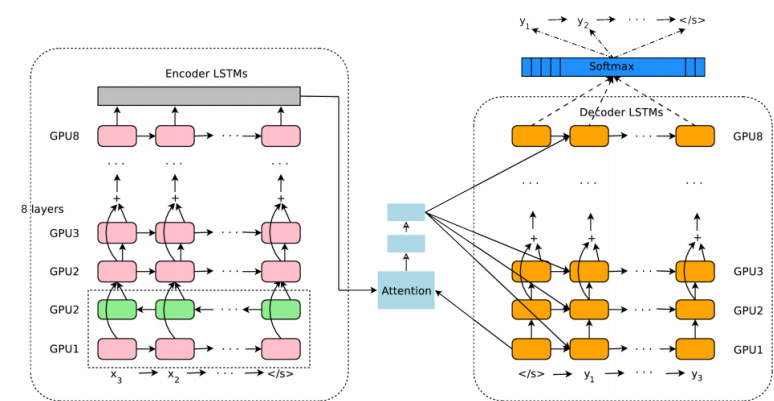

- Google's LSTM-based machine translation.

Wu et al. *arXiv:1609.08144* (2016).

44

## Limitations

- Discriminative vs. generative learning.
  - Discriminative:  $P(\text{class}|\text{data})$ . Can easily be fooled with adversarial input.
  - Generative:  
 $P(\text{class}, \text{data}) = P(\text{class}|\text{data})P(\text{data})$ . Explicitly models the data.
- Deep neural nets mostly use discriminative learning, so can be fooled by adversarial input. Generative adversarial learning can overcome this (Goodfellow et al. *arXiv:1406.2661* (2014)).

45

## Summary

- Deep belief network: Based on Boltzmann machine. Elegant theory, good performance.
- Deep convolutional networks: High computational demand, over the board great performance.
- Deep Q-Network: unique approach to reinforcement learning. End-to-end machine learning. Super-human performance.
- Deep recurrent neural networks: sequence learning. LSTM a powerful mechanism.
- Diverse applications. Top performance.
- Flood of deep learning tools available.

47

## Deep Learning Tools

- Kaffe: UC Berkeley's deep learning tool box
- TensorFlow (Google)
- Deep learning modules for Torch (Facebook)
- Microsoft CNTK (Computational Network Tool Kit)
- Other: Apache Mahout (MapReduce-based ML)

46