

CHAPTER 4

System Reliability

Introduction

A system is a set of components arranged to accomplish a purpose or purposes under a given set of conditions. This chapter is concerned with determining the reliability characteristics of the system from the statistical information available on the failure and repair cycles of the components. Non-maintained systems are treated extensively in the literature and therefore the attention in this book is directed towards maintainable systems. In these systems, restorative action is initiated immediately after the failure and reliability modelling and evaluation is generally more complicated than in non-maintained cases. The theory and procedure is, however, quite general and can be equally applied to non-maintainable systems.

Numerical values of reliability measures can be obtained either through simulation or by solving mathematical models. The simulation approach is discussed in Chapter 7. This chapter describes various mathematical approaches to system reliability evaluation. The essential theory has already been outlined in the previous two chapters. Different approaches to system representation and solution are described. The following preliminary analysis is basic to all the approaches.

Definition and Description of the System and its Requirements

The first step in developing a reliability model is to define and describe the system and its requirements. The system must be categorized into major subsystems and the function of each subsystem and the interface between them defined. It is helpful to prepare a functional diagram showing the interaction of the various subsystems. A statement of the function of each subsystem and component should also be prepared. This type of information is easy to obtain for existing systems or systems where the design is in the final stage. At the early stages of a project, a good description of the system may not exist and the reliability engineer may have to come up with a reasonable description of the system from the study reports, development plans and specifications. Discussions with other personnel engaged on the project are very helpful. The system can be usually broken down into convenient blocks and most often the systems are designed on that basis. In terms of developing a model for the reliability

calculations, it may sometimes be preferable to group the components from one natural subsystem into another to create independent subsystems as this facilitates the reliability calculations.

Failure Modes and Effects Analysis

The analysis has to start at the level at which the information is available or can be made available. The term component is used in a general sense as it may in itself be a subsystem. For example, in generating capacity reliability analysis, a generating unit is regarded as a component whereas it is in itself a complex of components. The failure modes of the components should be investigated. The different modes are recognized from the different effects which they may have on the system. Some components may have just one mode of failure whereas others may have several. A relay or a circuit breaker may, for example, fail in an open or closed position. These modes generally have different effects on the system. A diode may for example fail as open circuited or short circuited and these failures develop into different system contingencies. After the different modes have been identified, their effects on the system should be studied. To assure complete systematic coverage of the effects of various failure modes, it is useful to employ some type of recording forms. It is again stressed that the identification of the failure modes is based on the different effects which these modes may have on the system. After the first analysis has been performed it may turn out that some of the effects, different though they may be, can be regarded as identical from the point of view of reliability analysis. It may therefore be possible to reduce the modes of failure. It is advisable to keep the failure modes to a minimum both from the point of view of reducing the complexity of the problem as well as from the point of view of limited statistical data. It is also sometimes possible to regard the different failure modes as independent without introducing any significant error. In such a case the component can be represented by a number of independent binary components equal to the failure modes.

The detailed form of above qualitative analysis is commonly referred to as FMEA (Failure Mode Effects Analysis). In certain programs which involve the limited production of complex and costly new hardware, it may not be possible to go much beyond this point and certain conclusions regarding design weaknesses may be derived from this type of analysis. Criticality analysis may be further added by ranking the critical failure mode effects according to the probability of occurrence. This is then called FMECA (Failure Mode, Effects and Criticality Analysis). This has been used extensively by NASA and other defence industries and is now finding its way into the analysis of commercial systems.

The purpose of the above two steps is to deepen systematically the understanding of the system in terms of the various component failure

contingencies. In some cases the system may be simple or so well known that it may be possible to by-pass this analysis because it is intuitively known to the reliability engineer. Assuming that the above analysis has been performed or the system is intuitively well understood, the techniques for mathematically deriving the reliability measures can be broadly classified as:

- i. state space approach
- ii. decomposition using conditional probability approach
- iii. network method

These techniques are now described in detail.

State Space Approach

A component may assume various states depending upon its failure and restorative modes. The system state describes the states of the components and the environment in which the system is operating. The set of all the possible states of the system is called the state space or event space. If the environment can exist in m states and the n components of the system are independent in each environment state, then the state space consists of 2^{n+m} states. The number of states is, however, modified because of the dependency restrictions. The state space approach involves the following steps:

- i. Enumerate all possible system states.
- ii. Determine the interstate transition rates. If a diagram is drawn showing the various states and the interstate transition rates, it is called the state transition diagram.
- iii. If the components are independent, the system state probabilities may be found from the component state probabilities by the product rule. In case of dependent failures, the system equations are formed and solved for the state probabilities.
- iv. The states are then grouped into subsets depending upon the requirements of the analysis. In most cases, measures are required only for success or failure but in some cases the indices may be computed for a graded mode of operation. After the grouping has been done, the subset probabilities, frequencies, cycle time and mean duration can be computed by the application of the formulae given in Chapter 3.

This approach is conceptually general and flexible and makes it possible to take into account various dependent failures. In large systems, especially involving dependent failures, it may be difficult to apply this technique. The methods for overcoming these difficulties are discussed in the next chapter. This approach is illustrated with the help of the following simple example.

System Description

The system consists of line 1 and line 2 supplying electric power to bus C from buses A and B. The supply at points A and B is considered to be perfectly reliable. Line 1 supplies 75% of the total power and line 2 supplies the remaining 25%. The lines can exist either in the 'up' or the 'down' state and the repair facilities are sufficient to perform repair on both the lines at the same time. The system is considered failed when it is supplying less than 75% of the power.

State Transition Diagram

In evolving the state transition diagram it is usually convenient to start from the state in which all the components are in a working condition. This condition is represented by state 1 in Fig. 4.1. The states to which the system can transit from state 1 are determined by the component transition modes and either of the lines can fail giving state 2 or 3. If the up times of both the lines are exponentially distributed with mean up times T_1 and T_2 , the transition rates from state 1 to states 2 or 3 are constant and given by

$$\lambda_1 = \frac{1}{T_1}, \quad \lambda_2 = \frac{1}{T_2}$$

This is shown in step 1.

Consider states 2 and 3 where one component is failed and the other is working. The system can change state either because of the failure of the working component or because of the repair of the failed component. If component 1 were to fail in state 2, the resulting state description would be (1D,2D) as shown by state 4 in step 2 in Fig. 4.1. Since the failure rate λ_1 is constant for component number 1, it is unaffected by the time of residence in state 1 or state 2. If, however, the distribution were non-exponential, the transition rate would be dependent on times of residence and such a simple representation is not possible. This will be treated in detail in Chapter 6. Now considering state 3, if component 2 fails the system will transit to state 4 already generated but if component 1 is repaired, the system goes back to state 1. This is shown in step 2.

In state 4, both the components are down. Since both the components can be repaired independently, the resulting diagram is shown in step 3. The state transition diagram for this system is simple and could have been drawn in a straight-forward manner without going through the above procedure. The purpose of the above discussion is, however, to illustrate the concept of evolving the state transition diagram by examining the possible transition modes of each component in a particular system state. It should be realized that

it is not possible to draw a state transition diagram for relatively large systems. The above procedure is, however, readily programmable on the computer. The states in the computer program are represented by binary numbers, usually 0 standing for working components and 1 for failed ones. Special codes are employed for representing other modes (i.e. stand-by). The computer program usually evolves the state transition matrix directly and further manipulations are done using this matrix.

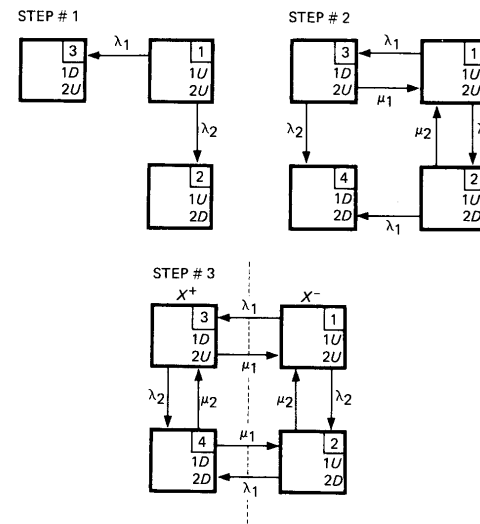

Fig. 4.1 Evolution of the state transition diagram.

State Probabilities

Both the lines are independent and the state probabilities can therefore be found by the simple product rule. It should be noted from Fig. 4.1 that when all the components are independent, each component can exert all its transition modes without any restriction from the other components or the environment. If in any system state, one or more of the transition modes of a component are suppressed, the components are no longer independent. Denoting the probabilities of the i th component being in the up or down state by $p_{iu}(t)$ and $p_{id}(t)$, these values for the initial condition $p_{iu}(0) = 1, p_{id}(0) = 0$ can be written from the results of the first chapter

$$p_{iu}(t) = \frac{\mu_i}{\lambda_i + \mu_i} + \frac{\lambda_i}{\lambda_i + \mu_i} e^{-(\lambda_i + \mu_i)t}$$

$$p_{id}(t) = \frac{\lambda_i}{\lambda_i + \mu_i} - \frac{\lambda_i}{\lambda_i + \mu_i} e^{-(\lambda_i + \mu_i)t}$$

The steady state values are

$$p_{iu} = \frac{\mu_i}{\lambda_i + \mu_i}$$

$$p_{id} = \frac{\lambda_i}{\lambda_i + \mu_i}$$

The state probabilities are

$$p_1(t) = p_{1u}(t)p_{2u}(t)$$

$$p_2(t) = p_{1u}(t)p_{2d}(t)$$

$$p_3(t) = p_{1d}(t)p_{2u}(t)$$

and

$$p_4(t) = p_{1d}(t)p_{2d}(t)$$

Reliability Measures

Since the system is considered failed if less than 75% of the total electric power is transferred, the subset X^+ of failed states is

$$X^+ = \{3, 4\}$$

and the disjoint subset X^- is

$$X^- = \{1, 2\}$$

The various measures can now be calculated

Time specific domain

The probability of the system being in the failed state at time t

$$= \text{The time specific availability of } X^+ = A_+(t)$$

$$= \sum_{i \in X^+} p_i(t)$$

$$\begin{aligned} &= p_3(t) + p_4(t) \\ &= p_{1d}(t)(p_{2u}(t) + p_{2d}(t)) \\ &= p_{1d}(t) \\ &= \frac{\lambda_1}{\lambda_1 + \mu_1} - \frac{\lambda_1}{\lambda_1 + \mu_1} e^{-(\lambda_1 + \mu_1)t} \end{aligned} \quad (4.1)$$

Fractional duration

$$\begin{aligned} &= D_+(0, T) \\ &= \frac{1}{T} \int_0^T A_+(t) dt \\ &= \frac{\lambda_1}{(\lambda_1 + \mu_1)T} \left[T + \frac{e^{-(\lambda_1 + \mu_1)T}}{\lambda_1 + \mu_1} - \frac{1}{\lambda_1 + \mu_1} \right] \\ &= \frac{\lambda_1}{\lambda_1 + \mu_1} \left[1 + \frac{1}{T(\lambda_1 + \mu_1)} (e^{-(\lambda_1 + \mu_1)T} - 1) \right] \end{aligned} \quad (4.2)$$

Interval frequency

$$\begin{aligned} &= F_+(0, T) \\ &= \int_0^T (p_1(t) + p_2(t)) \lambda_1 dt \\ &= \int_0^T p_{1u}(t) \lambda_1 dt \\ &= \frac{\lambda_1}{\lambda_1 + \mu_1} \int_0^T (\mu_1 + \lambda_1 e^{-(\lambda_1 + \mu_1)t}) dt \\ &= \frac{\lambda_1}{\lambda_1 + \mu_1} \left[\mu_1 T + \frac{\lambda_1}{\lambda_1 + \mu_1} (1 - e^{-(\lambda_1 + \mu_1)T}) \right] \end{aligned} \quad (4.3)$$

Steady State Analysis

The steady state measures can be obtained either by finding the limiting values of the time specific results or else by the direct application of the steady state formula. The latter approach is usually easier.

System unavailability

$$\begin{aligned}
 &= \text{The availability of } X^+ \\
 &= p_{1d} \\
 &= \frac{\lambda_1}{\lambda_1 + \mu_1}
 \end{aligned}$$

It should be noted that this result could also have been obtained either from Equation (4.1) by letting $t \rightarrow \infty$ or from Equation (4.2) as $T \rightarrow \infty$. The steady state unavailability can be interpreted, as mentioned before, either as the probability of being in the failed state at a point very remote from time of origin or as the limiting proportion of interval $(0, T)$ spent in the failed state, when T is very large. Frequency of encountering the failed state

$$\begin{aligned}
 &= (p_1 + p_2)\lambda_1 \\
 &= p_{1u}\lambda_1 \\
 &= \frac{\mu_1 \lambda_1}{\mu_1 + \lambda_1} \\
 &= p_{1d}\mu_1 \\
 &= \frac{\lambda_1 \mu_1}{\mu_1 + \lambda_1}
 \end{aligned}$$

This illustrates the frequency balance between the failed and working system state. The frequency could also be found from Equation (4.3)

by letting $T \rightarrow \infty$, in $F_+(0, T)/T$

Mean cycle Time

$$\begin{aligned}
 &= 1/\text{Frequency} \\
 &= \frac{\mu_1 + \lambda_1}{\mu_1 \lambda_1}
 \end{aligned}$$

Mean duration of the down state

$$\begin{aligned}
 &= \text{Mean cycle time} \times \text{unavailability} \\
 &= \frac{1}{\mu_1}
 \end{aligned}$$

The following section examines some basic configurations which occur quite commonly as systems or subsystems.

Series System

Components are considered to be in series when the failure of any one of the components causes system failure. This is shown in Fig. 4.2 where the failure of a component is equivalent to the removal of the corresponding block. It should be noted that the actual configuration of the components may or may not be in series, it is the effect of the failure of each component that is important. There are now two cases, firstly when all the components are independent and secondly



Fig. 4.2 Reliability diagram of n components in series

when after the system failure no further failure is possible so that there can be only one component in the failed state at any time. These two cases are considered separately.

Independent Case

Since the components are independent, the state probabilities can be derived from the component probabilities by the product rule. The state space will consist of $n+1$ subsets of states having $0, 1, \dots, n$ components in the failed state. The failure of even a single component causes system failure and therefore all the states except the one in which all the components are working represent system failure. It is therefore necessary to determine the measures for subset X^+ such that

$$\begin{aligned}
 X^- &= \{\text{state where all components are up}\} \\
 X^+ &= \{\text{all states except the one defined above}\} \\
 A_+(t) &= 1 - A_-(t) \\
 &= 1 - p_{1u}(t)p_{2u}(t) \dots p_{nu}(t)
 \end{aligned}$$

It can be seen that the above expression will involve exponential terms and the fractional duration and the interval frequency of the system failed state can be readily found by the application of appropriate formulae. In maintainable systems the steady state values are usually of primary importance and can be obtained from the following explicit formulae for this case.

System Unavailability

$$= 1 - p_{1u}p_{2u} \dots p_{nu}$$

$$= 1 - \frac{\mu_1\mu_2 \dots \mu_n}{(\lambda_1 + \mu_1)(\lambda_2 + \mu_2) \dots (\lambda_n + \mu_n)}$$

The frequency of encountering the down state

$$= A - \sum_{i=1}^n \lambda_i$$

$$= \frac{\mu_1\mu_2 \dots \mu_n(\lambda_1 + \lambda_2 + \dots + \lambda_n)}{(\lambda_1 + \mu_1)(\lambda_2 + \mu_2) \dots (\lambda_n + \mu_n)}$$

Mean cycle time to encounter the system down state

$$= \frac{(\lambda_1 + \mu_1)(\lambda_2 + \mu_2) \dots (\lambda_n + \mu_n)}{\mu_1\mu_2 \dots \mu_n(\lambda_1 + \lambda_2 + \dots + \lambda_n)}$$

Mean down time

$$= (\text{M.C.T.})(\text{Unavailability})$$

$$= \frac{(\lambda_1 + \mu_1)(\lambda_2 + \mu_2) \dots (\lambda_n + \mu_n)}{\mu_1\mu_2 \dots \mu_n(\lambda_1 + \lambda_2 + \dots + \lambda_n)} - \frac{1}{\lambda_1 + \lambda_2 + \dots + \lambda_n}$$

It should be noted that in the above expression the first term is the mean cycle time and the second term can be easily seen to be the mean up time. The mean down time is therefore represented as the difference of mean cycle time and the mean up time. For a two unit series system the expression for mean down time reduces to

$$\frac{1}{(\lambda_1 + \lambda_2)} \left[\frac{(\lambda_1 + \mu_1)(\lambda_2 + \mu_2)}{\mu_1\mu_2} - 1 \right]$$

$$= \frac{\lambda_1\mu_2 + \lambda_2\mu_1 + \lambda_1\lambda_2}{(\lambda_1 + \lambda_2)\mu_1\mu_2}$$

$$= \frac{\lambda_1r_1 + \lambda_2r_2 + \lambda_1\lambda_2r_1r_2}{\lambda_1 + \lambda_2} \tag{4.4}$$

where r_1 and r_2 are the mean down times for components 1 and 2.

Dependent Failure

In many series systems it is safe to assume that once the system has failed, further failures will not occur. In such a case the state transition diagram is shown in Fig. 4.3. State 0 corresponds to the working state when all components are up. State $i, i=1, \dots, n$, corresponds to the i th component down. Once the system enters any of these states it can return only to the working state 0 because further failures are impossible. The transient solution can be obtained by solving the state differential equations. The steady state solution proceeds in the following manner. The frequency balance equations can be written as follows.

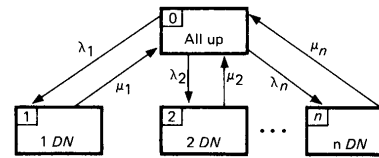

Fig. 4.3 A series system with dependent failure.

$$p_0 \sum_{j=1}^n \lambda_j = \sum_{i=1}^n p_i \mu_i \tag{4.5}$$

$$p_i \mu_i = p_0 \lambda_i \tag{4.6}$$

From Equation (4.6)

$$p_i = \frac{\lambda_i}{\mu_i} p_0$$

Substituting these values in equation

$$p_0 + \sum_{i=1}^n p_i = 1$$

$$p_0 = \frac{1}{Z}$$

where

$$Z = 1 + \sum_{i=1}^n \frac{\lambda_i}{\mu_i}$$

and

$$p_i = \frac{\lambda_i}{\mu_i Z}$$

System unavailability

$$= \sum_{i=1}^n p_i$$

$$= \frac{1}{Z} \sum_{i=1}^n \frac{\lambda_i}{\mu_i}$$

Frequency of encountering the down state

$$= p_0 \sum_{i=1}^n \lambda_i$$

$$= \frac{1}{Z} \sum_{i=1}^n \lambda_i$$

Mean cycle time

$$= Z / \sum_{i=1}^n \lambda_i$$

Mean Down Time

$$= (\text{M.C.T.})(\text{Unavailability})$$

$$= \sum_{i=1}^n \frac{\lambda_i}{\mu_i} / \sum_{i=1}^n \lambda_i$$

$$= \sum_{i=1}^n \lambda_i r_i / \sum_{i=1}^n \lambda_i \tag{4.7}$$

Referring to Equation (4.4), in high reliability component systems, the term $\lambda_1 \lambda_2 r_1 r_2$ can be neglected and therefore in such cases the mean down time is approximately the same in both the cases.

Series System with Spare

Consider the special case of a series system with a spare. The example chosen consists of a bank of three single phase transformers. As soon as a transformer fails, the entire bank is shut down until the failed unit has been replaced by the spare. The repair facilities are assumed to be unrestricted, i.e. as soon as the transformer fails, the repair is started irrespective of the fact that another unit may also be undergoing repair. The down time consists of two phases, the

repair time and the change out or the re-installation period. The following symbols are used:

- λ = failure rate of a single phase transformer
- μ = repair rate
- γ = installation rate

The up time and the down times are assumed to be exponentially distributed. Reliability modelling of this system when the down times are not exponentially distributed is discussed in Chapter 6. The state transition diagram is shown in Fig. 4.4. The subsets X^+ , X^- representing the system failed and working states can be defined as follows:

$$X^+ = \{3,4,5\}$$

$$X^- = \{1,2\}$$

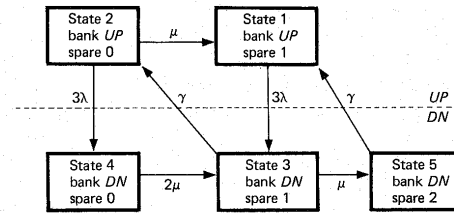

Fig. 4.4 The state transition diagram of a bank of three single phase transformers with one spare

The state frequency balance equations can be written as

$$3\lambda p_1 = \mu p_2 + \gamma p_5$$

$$(3\lambda + \mu)p_2 = \gamma p_3$$

$$(\gamma + \mu)p_3 = 3\lambda p_1 + 2\mu p_4$$

$$2\mu p_4 = 3\lambda p_2$$

$$\gamma p_5 = \mu p_3$$

Any four out of the above five equations together with the following equation can be used to obtain the steady state availabilities.

$$\sum_{i=1}^5 p_i = 1$$

The various probabilities obtained by solving these equations are:

$$p_1 = \frac{2\gamma^2\mu^2 + 2\gamma\mu^2(3\lambda + \mu)}{Z}$$

where

$$Z = 9\lambda^2\gamma^2 + 2\mu[(3\lambda + \mu)(3\lambda + \gamma)(\gamma + \mu)]$$

$$p_2 = \frac{6\lambda\gamma^2\mu}{Z} \quad p_3 = \frac{6\lambda\mu\gamma(3\lambda + \mu)}{Z}$$

$$p_4 = \frac{9\lambda^2\gamma^2}{Z} \quad p_5 = \frac{6\lambda\mu^2(3\lambda + \mu)}{Z}$$

$$p_{DN} = p_3 + p_4 + p_5 = \frac{9\lambda^2\gamma^2 + 6\lambda\mu\gamma(3\lambda + \mu) + 6\lambda\mu^2(3\lambda + \mu)}{Z}$$

and

$$p_{UP} = p_1 + p_2 = \frac{2\gamma^2\mu^2 + 2\gamma\mu^2(3\lambda + \mu) + 6\lambda\gamma^2\mu}{Z}$$

The frequency of encountering the subset X^+ of the failed states can be found as:

$$f_{X^+} = \sum_{\substack{m \in X^+ \\ k \in X^-}} p_m \lambda_{mk} = \sum_{\substack{k \in X^+ \\ m \in X^-}} p_k \lambda_{km}$$

It is more convenient here to use the first relationship

$$\begin{aligned} f_{UP} = f_{DN} &= 3\lambda(p_1 + p_2) \\ &= 3\lambda p_{UP} \\ &= \frac{3\lambda(2\gamma^2\mu^2 + 2\gamma\mu^2(3\lambda + \mu) + 6\lambda\gamma^2\mu)}{Z} \end{aligned}$$

The mean cycle time

$$\begin{aligned} &= 1/f_{DN} \\ &= \frac{Z}{3\lambda(2\gamma^2\mu^2 + 2\gamma\mu^2(3\lambda + \mu) + 6\lambda\gamma^2\mu)} \end{aligned}$$

The mean down time

$$\begin{aligned} &= (\text{M.C.T.}) \times (\text{Unavailability}) \\ &= \frac{9\lambda^2\gamma^2 + 6\lambda\mu\gamma(3\lambda + \mu) + 6\lambda\mu^2(3\lambda + \mu)}{3\lambda(2\gamma^2\mu^2 + 2\gamma\mu^2(3\lambda + \mu) + 6\lambda\gamma^2\mu)} \end{aligned}$$

Parallel Systems

When there are a number of components each one of them partially or completely serving the purpose, these components are said to be in parallel. When the components are simultaneously performing the same function so that the system will be fully available if at least one equipment is operating, it is said to be a parallel redundant configuration. In the example of two transmission lines of 25% and 75% of the total capacity requirements, this is a parallel but not a redundant arrangement. The following section deals with parallel redundant configurations. If the failure and repair rates of the equipment can be regarded as independent of the environment, the components can be usually regarded as independent. The probability of the system being in the down state at time t , i.e. the unavailability, can be found by the product rule

$$U(t) = p_{1d}(t)p_{2d}(t) \dots p_{nd}(t)$$

This product will be a function of exponential terms which are easily integrable. The fractional duration or the average down time in the interval $(0, t)$ can be therefore easily determined. For determining the interval frequency, the states in X^- from which the system can transit to X^+ in a single transition have to be identified. These states are called the boundary states and it is these states which contribute to interval frequency, the transitions from other states of X^- remaining within the subset. In the present example, these states are obviously those in which only one component is in the working state. The number of such states is obviously n . The time specific frequency of encountering the down state is

$$f_{DN}(t) = \sum_{i=1}^n p_{iu}(t) \lambda_i \prod_{\substack{j=1 \\ j \neq i}}^n p_{jd}(t)$$

and

$$f_{DN}(0, t) = \int_0^t f_{DN}(x) dx$$

The steady state results which are of main interest can be, however, more readily obtained in explicit form

$$U = \text{Unavailability} = \prod_{i=1}^n \frac{\lambda_i}{\lambda_i + \mu_i}$$

It has been explained previously that in the steady state condition, there is a frequency equilibrium between X^- and X^+ . The frequency can therefore be found for either of these two subsets. In practice, the one which is easiest to compute. In this case it is obvious that the easiest way is to find the frequency

of encountering the up state since there is only one state in the down state. Therefore

$$f_{DN} = f_{UP} = \left(\prod_{i=1}^n \frac{\lambda_i}{\lambda_i + \mu_i} \right) \sum_{i=1}^n \mu_i$$

The same result is derived for the sake of completeness as encounters from X^- to X^+ .

$$f_{DN} = \sum_{i=1}^n p_{iu} \lambda_i \prod_{\substack{j=1 \\ j \neq i}}^n p_{jd}$$

$$= \sum_{i=1}^n \mu_i \prod_{j=1}^n p_{jd}$$

$$= \left(\prod_{j=1}^n p_{jd} \right) \sum_{i=1}^n \mu_i$$

$$= \left(\prod_{i=1}^n \frac{\lambda_i}{\lambda_i + \mu_i} \right) \sum_{i=1}^n \mu_i$$

which is the same as derived above. The mean cycle time to encounter to the down state is the reciprocal of the frequency. The mean down time

$$= U/f_{DN}$$

$$= \frac{1}{\sum_{i=1}^n \mu_i}$$

The m/n Parallel System

In some systems of identical parallel components, m out of n components may be required for successful operation. These are termed m/n parallel systems and can be represented as shown in Fig. 4.5.

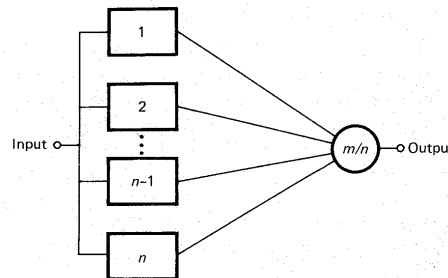

Fig. 4.5 The m/n Representation

If the components are independent, the reliability measures can be easily derived. Assuming identical failure and repair rates λ and μ

$U =$ Unavailability

$$\begin{aligned} &= \binom{n}{m-1} \left[\frac{\mu}{\lambda + \mu} \right]^{m-1} \left[\frac{\lambda}{\lambda + \mu} \right]^{n-m+1} \\ &+ \binom{n}{m-2} \left[\frac{\mu}{\lambda + \mu} \right]^{m-2} \left[\frac{\lambda}{\lambda + \mu} \right]^{n-m+2} + \dots + \binom{n}{0} \left[\frac{\lambda}{\lambda + \mu} \right]^n \\ &= \frac{1}{(\lambda + \mu)^n} \sum_{r=0}^{m-1} \binom{n}{r} \mu^r \lambda^{n-r} \end{aligned}$$

For calculating the frequency of encountering the down state, the boundary states in X^- are those in which m units are working and $n-m$ are failed. Any further component failure results in system failure. The frequency is therefore

$$f_{DN} = \binom{n}{m} \frac{\mu^m \lambda^{n-m}}{(\lambda + \mu)^n} m \lambda$$

The mean cycle time can be found as a reciprocal of f_{DN} and the mean down time

$$= U/f_{DN}$$

Decomposition Using the Conditional Probability Approach

This method consists of decomposing a complex system into simple subsystems by the successive application of the conditional probability theorem. The idea is to calculate the reliability measures of the simpler subsystems and to combine these results to obtain the values for the system. The selection of the component or subsystem which is the key component or subsystem is therefore important. If this is not judiciously chosen, the final results will still be the same but the computation could be far more difficult. This method can be used to simplify both the state space as well as the network approach. Denoting the key component by X and representing the probability of its being up or down by $P(X)$ and $P(\bar{X})$ respectively

$$P_s = \text{Probability of system success} \\ = P(\text{System success} | X)P(X) + P(\text{System success} | \bar{X})P(\bar{X}) \quad (4.8)$$

and

$$P_f = \text{Probability of system failure} \\ = P(\text{System failure} | X)P(X) + P(\text{System failure} | \bar{X})P(\bar{X})$$

The formula for calculating the frequency of encountering the down state (or any other state or subset of states) has been derived by the authors in the analysis of interconnected electric power systems and is explained below. The frequency of encountering the failed state of the system consists of the following components:

- i. the frequency of encountering the failed state, the component X being up, denoted by f_1
- ii. the frequency of encountering the failed state, the component X being down, denoted by f_2
- iii. the frequency of encountering the failed state as a result of the failure of component X , denoted by f_3

The frequency being the expectation of the state encounter rate

$$f_f = \text{The frequency of encountering the system failure} \\ = f_1 + f_2 + f_3 \\ = f(\text{System failure} | X)P(X) + f(\text{System failure} | \bar{X})P(\bar{X}) + f_3$$

The expression for f_3 is now derived. Let the state space of the system be denoted by Y_0 and Y_1 given that X is up or down respectively. Let the subsets of the failed and working states be denoted by superscripts + and - respectively. Y_0^- thus denotes the set of working states given X is up and Y_1^+ denotes the set of failed states given that X is down. States in Y_0 and Y_1 having the same configuration of components, excluding X , are regarded as identical. It is assumed that the system cannot transit from the failed state to a working state by the failure of X . Therefore a state which is a member of Y_0^+ cannot be a member of

Y_1^- . The intersection of subsets Y_0^- and Y_1^+ represents the states in which the system is working if X is up but failed if X is down. Denoting these states by set S

$$f_3 = \sum_{i \in S} P(\text{State } i | X)P(X)\lambda_x$$

where

$$\lambda_x = \text{The failure rate of } X.$$

If the component X is independent of the rest of the system, then the sets Y_0 and Y_1 are equal and

$$P(\text{State } i | X) = P(\text{State } i | \bar{X})$$

Under this condition

$$\sum_{i \in S} P(\text{State } i | X) = \sum_{i \in Y_1^+} P(\text{State } i | \bar{X}) - \sum_{i \in Y_1^+} P(\text{State } i | X) \\ = P(\text{System failure} | \bar{X}) - P(\text{System failure} | X)$$

The formula for system failure frequency, therefore, becomes

$$f_f = f(\text{System failure} | X)P(X) + f(\text{System failure} | \bar{X})P(\bar{X}) \\ + (P(\text{System failure} | \bar{X}) - P(\text{System failure} | X))P(X)\lambda_x \quad (4.9)$$

The application of this approach in simplifying reliability block diagrams is shown later in the chapter; the application in a state space approach is shown in the following example, which is rather an oversimplification of interconnected power systems.

Example 4.1: The electric power to an area is supplied from Station A where two identical generating units 1 and 2 are installed. A generating unit 3 is installed at a remote place and is supplying power to the same area through a transmission line. The failure and repair rates of the generating units are assumed to be λ and μ respectively.

The failure and repair rate of the transmission line are λ_x and μ_x . The system is classified as failed when no supply is available at all.

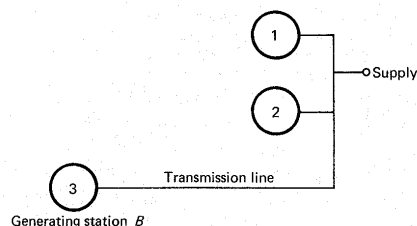

Fig. 4.6 Functional diagram of the generation scheme

Assuming the transmission line in the up state, the three units can be assumed as parallel, therefore

$$P(\text{System failure} | TL \text{ up}) = \left(\frac{\lambda}{\lambda + \mu} \right)^3$$

$$f(\text{System failure} | TL \text{ up}) = \left(\frac{\lambda}{\lambda + \mu} \right)^3 3\mu$$

Assuming the transmission line in the down state, the system is composed of only two parallel units, and therefore

$$P(\text{System failure} | TL \text{ dn}) = \left(\frac{\lambda}{\lambda + \mu} \right)^2$$

$$f(\text{System failure} | TL \text{ dn}) = \left(\frac{\lambda}{\lambda + \mu} \right)^2 2\mu$$

$$P_f = \left(\frac{\lambda}{\lambda + \mu} \right)^3 \frac{\mu_x}{\lambda_x + \mu_x} + \left(\frac{\lambda}{\lambda + \mu} \right)^2 \frac{\lambda_x}{\lambda_x + \mu_x}$$

$$= \frac{1}{\lambda_x + \mu_x} \left(\frac{\lambda}{\lambda + \mu} \right)^2 \left[\frac{\lambda \mu_x}{\lambda + \mu} + \lambda_x \right]$$

$$f_f = \left(\frac{\lambda}{\lambda + \mu} \right)^3 3\mu \frac{\mu_x}{\lambda_x + \mu_x} + \left(\frac{\lambda}{\lambda + \mu} \right)^2 2\mu \frac{\lambda_x}{\lambda_x + \mu_x}$$

$$+ \left[\left(\frac{\lambda}{\lambda + \mu} \right)^2 - \left(\frac{\lambda}{\lambda + \mu} \right)^3 \right] \frac{\mu_x \lambda_x}{\lambda_x + \mu_x}$$

$$= \left(\frac{\lambda}{\lambda + \mu} \right)^3 \frac{3\mu \mu_x}{\lambda_x + \mu_x} + \left(\frac{\lambda}{\lambda + \mu} \right)^2 \frac{2\mu \lambda_x}{\lambda_x + \mu_x} + \left(\frac{\lambda}{\lambda + \mu} \right)^2 \frac{\mu}{\lambda + \mu} \frac{\mu_x \lambda_x}{\lambda_x + \mu_x}$$

The same result can be obtained by drawing the state space diagram and making the calculations. This exercise is left to the reader for verification.

Network Approach

The state space approach is general and flexible but it becomes cumbersome when the number of states becomes large. The network approach when applicable usually provides a shorter route to solution. The network approach is usually not suitable when dependent failures or repairs are involved. Such failures occur in standby systems, interactive systems or systems whose failure and repair rates respond to a fluctuating common environment. It is not necessary to assume the event independence in this approach, but dependent events can greatly increase the algebra of computations and sometimes the solution may become impossible. At this point it is necessary to recognize the difference between two types of block diagrams.

Physical or Block Schematic Diagram

This diagram describes the actual connections between the components. Each block is a component and the diagram shows the manner in which they are actually connected.

Logic Diagram or Reliability Block Diagram

This diagram describes logical connections between components. Each block is a component which is removed when the component fails and replaced when it is repaired. The connections between the blocks describe the success or failure of the system as a function of the states of the component.

In the block schematic diagram, a component is not repeated because it represents the physical reality but in the reliability block diagram the block may be repeated. It is generally easy to construct the physical diagram as it follows from the physical layout. The reliability block diagram is usually difficult to prepare and in some cases a unique diagram may not exist. In the cases of information or power flow systems, it may be easy to construct a reliability block diagram. In many cases it may be difficult to do so. It requires a thorough understanding of the system and it is advisable to perform FMEA before constructing this block diagram. In the methods described below, the following assumptions are utilized.

1. the system is composed of independent components or subsystems. When the component reliabilities are high, this assumption enables approximate results to be obtained for non-independent units. Approximate formulae are also available for the reliability of a parallel network when the components respond to a two state fluctuating environment

2. each component or subsystem can be represented by a two state device, and the system success or failure can be expressed in terms of these two state devices
3. when all the components are working, the system is successful and when all the components are failed, the system is failed
4. when a group of components is working and the system is successful, the restoration of a failed component will not cause system failure
5. when a group of components is failed and the system is failed, the failure of any additional component will not restore the system to a successful state.

As the components are assumed to be independent it is not necessary to assume any particular distribution form for the up and down times in order to obtain steady state results. This will be clarified further in Chapter 6. It is only necessary to know the mean up and down times. The reciprocals of the mean up times and mean down times are failure and repair rates respectively. Assuming that the reliability block diagram exists, there are two main methods, the reliability diagram reduction method and a method based on manipulating the cut sets or tie sets. Both of these methods will now be described in detail.

Network Reduction Procedure

This method proceeds by the manipulation of the basic network structures:

- i. series structures
- ii. parallel structures
- iii. *m/n* structures when the *n* blocks originate from a common node

The method sequentially reduces the simple structures to equivalent units until the whole network reduces to a single unit. The necessity of assuming subsystem independence will be made clear in the next chapter while discussing the validity of equivalent transition rates in the context of subsystem reduction. Assuming that no subsystem is represented by more than one block, the procedure is as follows:

1. replace all series blocks by an equivalent block. In this case the following measures of the equivalent block can be easily obtained

$$\text{Availability} = \prod_{\forall i} p_{iu}$$

$$\text{Failure rate} = \sum_{\forall i} \lambda_i$$

2. in the resultant diagram replace the parallel and *m/n* substructures by equivalent blocks. In the parallel block diagrams it is convenient to determine the following measures of the equivalent block

$$\text{Unavailability} = \prod_{\forall i} p_{id}$$

$$\text{Repair rate} = \sum_{\forall i} \mu_i$$

The above steps are repeated until the whole network reduces to an equivalent block. If at any stage the network does not reduce any further, then the decomposition approach may be employed to generate simpler networks. In applying the decomposition approach to networks, the condition that the key component is good is equivalent to replacing this component by a short circuit and the condition that this component is down is equivalent to replacing it by an open circuit. This approach is illustrated by application to the system shown in Fig. 4.6. The reliability block diagram follows directly from the system topology and is shown in Fig. 4.7.

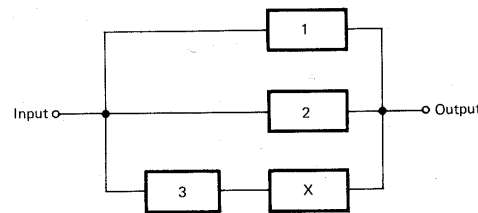

Fig. 4.7 Reliability block diagram of the system shown in Fig. 4.6

In this diagram, blocks 3 and X are in series. The equivalent block 3X has the following measures

$$p_{3xd} = 1 - p_{3u}p_{xu}$$

$$\lambda_{3x} = \lambda_3 + \lambda_x$$

Components 1, 2 and 3X are now in parallel, therefore

$$\text{Unavailability} = p_{1d}p_{2d}p_{3xd} = p_{1d}p_{2d} - p_{1d}p_{2d}p_{3u}p_{xu}$$

$$\begin{aligned}
 &= p_{1d}p_{2d} - p_{1d}p_{2d}(1 - p_{3d})p_{xu} \\
 &= p_{1d}p_{2d}(1 - p_{xu}) + p_{1d}p_{2d}p_{3d}p_{xu} \\
 &= p_{1d}p_{2d}p_{xd} + p_{1d}p_{2d}p_{3d}p_{xu} \\
 &= \left(\frac{\lambda}{\lambda + \mu}\right)^2 \frac{\lambda_x}{\lambda_x + \mu_x} + \left(\frac{\lambda}{\lambda + \mu}\right)^3 \frac{\mu_x}{\lambda_x + \mu_x}
 \end{aligned}$$

This result is the same as obtained in Example 4.1. The repair rate of the block 3X can be derived from

$$\begin{aligned}
 \frac{\lambda_{3x}}{\lambda_{3x} + \mu_{3x}} &= U_{3x} = 1 - p_{3u}p_{xu} \\
 \text{i.e.} \quad \mu_{3x} &= \frac{\lambda_{3x}}{1 - p_{3u}p_{xu}} - \lambda_{3x} \\
 &= \lambda_{3x}p_{3u}p_{xu} / (1 - p_{3u}p_{xu})
 \end{aligned}$$

The frequency of system failure

$$\begin{aligned}
 &= \text{System Unavailability} \sum_i \mu_i \\
 &= p_{1d}p_{2d}(1 - p_{3u}p_{xu})(\mu_1 + \mu_2 + \mu_{3x}) \\
 &= 2\mu \left[\left(\frac{\lambda}{\lambda + \mu}\right)^2 \frac{\lambda_x}{\lambda_x + \mu_x} + \left(\frac{\lambda}{\lambda + \mu}\right)^3 \frac{\mu_x}{\lambda_x + \mu_x} \right] \\
 &\quad + p_{1d}p_{2d}(\lambda_3 + \lambda_x)p_{3u}p_{xu} \\
 &= 2\mu \left[\left(\frac{\lambda}{\lambda + \mu}\right)^2 \frac{\lambda_x}{\lambda_x + \mu_x} + \left(\frac{\lambda}{\lambda + \mu}\right)^3 \frac{\mu_x}{\lambda_x + \mu_x} \right] \\
 &\quad + \left(\frac{\lambda}{\lambda + \mu}\right)^2 (\lambda + \lambda_x) \frac{\mu}{\lambda + \mu} \frac{\mu_x}{\lambda_x + \mu_x} \\
 &= \left(\frac{\lambda}{\lambda + \mu}\right)^3 \frac{3\mu\mu_x}{\lambda_x + \mu_x} + \left(\frac{\lambda}{\lambda + \mu}\right)^2 \frac{2\mu\lambda_x}{\lambda_x + \mu_x} \\
 &\quad + \left(\frac{\lambda}{\lambda + \mu}\right)^2 \frac{\mu}{\lambda + \mu} \frac{\mu_x}{\lambda_x + \mu_x}
 \end{aligned}$$

which is the same as derived in Example 4.1. It should be noted that though the deriving of explicit expressions could be a formidable task, the numerical results even for large systems can be obtained easily using a calculator or a computer.

Example 4.2: The reliability block diagram of a system is shown in Fig. 4.8. The mean up times and down times of the various blocks are:

$$\begin{aligned}
 MUT_1 = MUT_2 = MUT_3 = MUT_4 = MUT_5 &= \frac{1}{2} Yr \\
 MDT_1 = MDT_2 = MDT_3 = MDT_4 = MDT_5 &= 20 \text{ Hr}
 \end{aligned}$$

Assuming that all components are statistically independent, calculate the reliability measures for continuity between *s* and *l*.

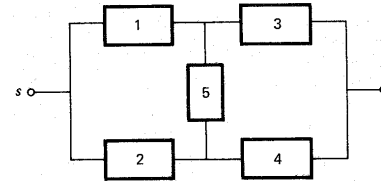

Fig. 4.8 Reliability block diagram for Example 4.2

It is obvious that no simple series or parallel paths exist in this reliability structure. Applying the principle of decomposition, the block diagram can be split into simple series and parallel configurations as shown in Fig. 4.9 in the form of a tree. Referring to Formulae (4.8) and (4.9), the values required are the probability and frequency of system failure given 5 is good and then given 5 is bad. The system measures can then be calculated in terms of these values.

The failure and repair rates of the components are:

$$\lambda_1 = \lambda_2 = \lambda_3 = \lambda_4 = \lambda_5 = \lambda$$

and

$$\mu_1 = \mu_2 = \mu_3 = \mu_4 = \mu_5 = \mu$$

The probability of a component being down

$$p_d = \frac{\lambda}{\lambda + \mu}$$

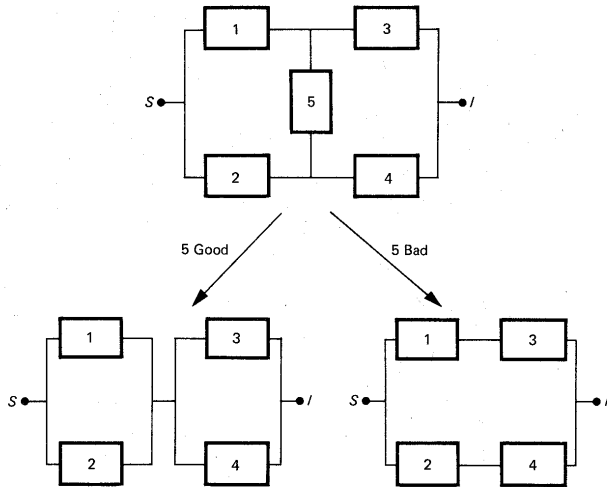

Fig. 4.9 Decomposition of a complex reliability block diagram into simple structures

Given 5 Good

$$p_{12d} = p_d^2$$

$$p_{12u} = 1 - p_{12d} = 1 - p_d^2$$

$$f_{12} = p_{12d}(\mu_1 + \mu_2)$$

$$= 2\mu p_d^2$$

The equivalent failure rate of component 12 is given by (3.37)

$$\lambda_{12} = f_{12}/p_{12u}$$

$$= 2\mu p_d^2 / (1 - p_d^2)$$

and the equivalent repair rate

$$\mu_{12} = f_{12}/p_{12d} = 2\mu$$

The values for the equivalent block 34 are the same as for 12 because they consist of identical components. The equivalent blocks 12 and 34 are in series and therefore

$$P(\text{System failure} | 5 \text{ Good}) = p_{1234d}$$

$$= 1 - p_{12u}p_{34u}$$

$$= 1 - (1 - p_d^2)^2 = 2p_d^2 - p_d^4$$

$$f(\text{System failure} | 5 \text{ Good}) = p_{1234u}(\lambda_{12} + \lambda_{34})$$

$$= 4\mu p_d^2(1 - p_d^2)$$

Given 5 Bad

$$p_{13u} = p_{1u}p_{3u} = (1 - p_d)^2$$

$$p_{13d} = 1 - p_{13u}$$

$$= 2p_d - p_d^2$$

$$f_{13} = p_{13u}(\lambda_1 + \lambda_3)$$

$$= (1 - p_d)^2 2\lambda$$

$$\mu_{13} = f_{13}/p_{13d}$$

$$= \frac{2\lambda(1 - p_d)^2}{2p_d - p_d^2}$$

$P(\text{System failure} | 5 \text{ Bad})$

$$= p_{1324d} = p_{13d}p_{24d}$$

$$= (2p_d - p_d^2)^2$$

$f(\text{System failure} | 5 \text{ Bad})$

$$= p_{1324u}(\mu_{13} + \mu_{24})$$

$$= (2p_d - p_d^2)^2 \frac{4\lambda(1 - p_d)^2}{2p_d - p_d^2}$$

$$= 4\mu p_d(1 - p_d)(2p_d - p_d^2)$$

These results can now be combined using formulae (4.8) and (4.9).

$$P_f = P(\text{System failure} | 5 \text{ Good})P(5 \text{ good})$$

$$+ P(\text{System failure} | 5 \text{ Bad})P(5 \text{ Bad})$$

$$= (2p_d^2 - p_d^4)(1 - p_d) + (2p_d - p_d^2)^2 p_d$$

$$= 2p_a^2 + 2p_a^3 - 5p_a^4 + 2p_a^5$$

and

$$\begin{aligned} f_f &= f(\text{System failure} | 5 \text{ Good})P(5 \text{ Good}) \\ &\quad + f(\text{System failure} | 5 \text{ Bad})P(5 \text{ Bad}) \\ &\quad + (P(\text{System failure} | 5 \text{ Bad}) \\ &\quad - P(\text{System failure} | 5 \text{ Good}))P(5 \text{ Good}) \cdot \lambda_s \\ &= 4\mu p_a^2(1 - p_a^2)(1 - p_a) + 4\mu p_a^2(2p_a - p_a^2)(1 - p_a) \\ &\quad + ((2p_a - p_a^2)^2 - 2p_a^2 + p_a^4)\mu p_a \\ &= \mu(4p_a^2 + 6p_a^3 - 20p_a^4 + 10p_a^5) \end{aligned}$$

$$\text{Mean cycle time} = 1/f_f$$

and

$$\text{Mean Down Time} = p_f/f_f$$

Cut Set or Tie Set Methods

The network reduction approach is quite useful when the block diagram consists essentially of series and parallel structures. When the reliability block diagram is complex, decomposition into simple series and parallel paths may not be easy. The process could be quite difficult to program because it would require a lot of scanning. The approach using cut sets or tie sets is especially useful for computer applications. The following definitions are useful in appreciating this approach.

Simple Path

If in going from node x to y no node is traversed more than once, the path is simple. For example, in Fig. 4.8, 1-5-4 is a simple path.

Connected Subnetwork

A subnetwork is said to be connected if there exists a simple path between all pair of nodes.

Cut Set

This is a set of components whose failure alone will cause system failure. A minimal cut has no proper subset of components whose failure alone will cause system failure.

The minimal cuts for the reliability block diagram shown in Fig. 4.8 are listed in Table 4.1.

Table 4.1 Minimal cuts between input and output nodes in Fig. 4.8

Minimal cut set	Components in the set
C_1	1, 2
C_2	3, 4
C_3	1, 4, 5
C_4	2, 3, 6

Path or Tie Set

This is a set of components whose functioning alone will guarantee system success. A minimal path or tie set has no proper subset of components whose functioning alone would ensure system success.

In this approach it is possible to proceed either through cut set manipulation or tie set manipulation. The choice is usually dictated by their relative numbers. Both methods are explained.

Tie Set Manipulation

In the minimal path all the blocks constituting it are in series. The failure of any one of these blocks would render that path ineffective. The minimal paths themselves are, however, in parallel as the system will be successful so long as there is even one path available between the input and output of the reliability block diagram. Denoting the path available and unavailable by T and \bar{T} respectively

$$\begin{aligned} P_s &= P(T_1 \cup T_2 \cup T_3 \cup \dots \cup T_m) \\ &= [P(T_1) + P(T_2) + P(T_3) + \dots + P(T_m)] \leftarrow \binom{n}{1} \text{ terms} \\ &\quad - [P(T_1 \cap T_2) + P(T_1 \cap T_3) + \dots + P(T_i \cap T_j)] \leftarrow \binom{n}{2} \text{ terms} \\ &\quad + [P(T_1 \cap T_2 \cap T_3) + P(T_1 \cap T_2 \cap T_4) + \dots \\ &\quad + P(T_i \cap T_j \cap T_k)] \leftarrow \binom{n}{3} \text{ terms} \\ &\quad \dots \end{aligned}$$

$$+ (-1)^{n-1} [P(T_1 \cap T_2 \cap \dots \cap T_n)] \left\langle \binom{n}{n} \right\rangle \text{ terms} \quad (4.10)$$

The total number of terms in this expression is $2^n - 1$ where n is the number of tie sets. It can be seen from Equation (4.10) that the independence of components need not be postulated. All that is needed is the evaluation of all the terms of the expansion (4.10). In the case of dependent failures, however, the entire state transition diagram may have to be drawn to evaluate the above terms. This method is therefore of importance for independent components. As the number of tie sets, however, increases, the expansion of all the terms becomes a formidable task. In such cases useful approximate formulae can be obtained by Boole's inequality.

$$P(T_1 \cup T_2 \cup \dots \cup T_n) \leq P(T_1) + P(T_2) + P(T_3) + \dots + P(T_n)$$

Therefore if only the first row in the expansion (4.10) is calculated, the result will be an upper bound approximation. This upper bound becomes a good approximation when the component reliabilities are low. As the components are assumed independent

$$P(T_i) = \prod_{j \in T_i} p_{ju}$$

When the number of tie sets is relatively small so that explicit relationships can be derived, the following procedure can be used to obtain exact values:

1. Calculate the tie set availabilities

$$P(T_i) = \prod_{j \in T_i} p_{ju}$$

2. The formula for system availability assuming the paths are independent is

$$P_s = 1 - \prod_{i=1}^n (1 - p(T_i))$$

3. Independence of paths has been assumed in the above expression. It will contain some terms containing p_{ju}^m . These terms are introduced due to the path independence assumption in calculating the 2nd to n th row in expansion (4.10). Therefore, the exact result for P_s may be obtained by replacing p_{ju}^m by p_{ju}^m . This procedure is, however, possible only when the number of tie sets is small and an explicit expression can be easily derived. When only the numerical results are to be obtained, either the expansion (4.10) may be evaluated or the upper bound approximation may be calculated.

Cut Set Manipulation

In the minimal cut the blocks are in parallel as all of them must fail, to produce a cut. The minimal cuts themselves are, however, in series as even a single cut ensures failure. Denoting the failure of the i th cut set by \bar{C}_i , the probability of system failure is

$$P_f = P(\bar{C}_1 \cup \bar{C}_2 \cup \bar{C}_3 \cup \dots \cup \bar{C}_m) \quad (4.11)$$

and

$$P_s = 1 - P_f$$

The Expression (4.11) can be expanded in the same manner as (4.10) and all the comments on (4.10) apply equally well to this expansion. By Boole's inequality

$$P_f \leq P(\bar{C}_1) + P(\bar{C}_2) + \dots + P(\bar{C}_m)$$

This upper bound of the probability of failure is useful in the high reliability region. The above inequality can be manipulated into the following form

$$P_s \geq 1 - [P(\bar{C}_1) + P(\bar{C}_2) + \dots + P(\bar{C}_m)]$$

This lower bound is good when the component reliabilities are high. The components being assumed independent

$$P(C_i) = 1 - \prod_{j \in C_i} p_{jd}$$

When the explicit formulae can be derived, the following procedure can be used to obtain the exact values.

1. Calculate the cut set availabilities

$$P(C_i) = 1 - \prod_{j \in C_i} p_{jd}$$

2. The formula for system success assuming the cut set independence is

$$P_s = \prod_{i=1}^m P(C_i)$$

3. Replace p_{ju}^m by p_{ju} , the resulting formula will be the exact expression for system reliability.

Frequency Calculation Using The Cut Set Approach

In order to understand the derivation of the failure frequency formula, the relationship between the minimal cut set and the system state-space should be understood. Consider a minimal cut set C_i which has components l and m as its members. This means that if the components l and m fail, the system will be failed irrespective of the states of the other components of the system. The failure of the members of C_i is equivalent to the system being in subset S_i of the state space S , where

$$S_i = \{s_j: \text{in the state } s_j, \text{ the components } l \text{ and } m \text{ are failed and the other components exist in a particular state}\}$$

The state s_j^v in which l and m are failed and all of the other components are functioning is called the vertex state of the subset S_i . The system can transit from the vertex state either upwards (in the sense of less components in the failed state) by the repair of the failed components l and m or it can transit downwards (in the sense of more components in the failed state) by the successive failures of more components. The subset S_i is constituted by the states generated by the downward transitions from s_j^v . The system could transit out of S_i by the repair of l or m and therefore the frequency of encountering subset S_i is

$$\begin{aligned} f_i &= \sum_{s_j \in S_i} P(s_j) \sum_{k \in C_i} \mu_k \\ &= \left(\sum_{k \in C_i} \mu_k \right) \left(\sum_{s_j \in S_i} P(s_j) \right) \\ &= \left(\sum_{k \in C_i} \mu_k \right) (P(S_i)) \\ &= \left(\sum_{k \in C_i} \mu_k \right) P(\bar{C}_i) \\ &= \bar{\mu}_i P(\bar{C}_i) \end{aligned}$$

where

$$\bar{\mu}_i = \sum_{k \in C_i} \mu_k$$

The relationship between the cut set and its equivalent state space subset can be more clearly understood by reference to Fig. 4.10 where the cut set C_1 of Fig. 4.8 and the equivalent subset S_1 are shown. $S_1 = \{s_1, s_2, \dots, s_8\}$. The states which are members of S_1 are generated by successive failures of components 3, 4 and 5 from the vertex state s_1 . From any state eS_1 , the system

could transit out of S_1 by the repair of component 1 or 2 which are the members of C_1 . The frequency of encountering S_1 is

$$\begin{aligned} f_1 &= (\mu_1 + \mu_2) \left[\sum_{i=1}^8 P(s_i) \right] \\ &= (\mu_1 + \mu_2) P(\bar{C}_1) \\ &= (\mu_1 + \mu_2) (p_{1a} p_{2a}) \end{aligned}$$

Now consider another minimal cut set C_k and its equivalent subset S_k of the state space S . The reader can appreciate the arguments by taking $C_k \equiv C_3$ in Fig. 4.10 where C_3 is the minimal cut set of Fig. 4.8. If S_i and S_k were mutually exclusive, there could not be any transition between S_i and S_k . This can be seen as follows. Suppose that from state s_i^v of subset S_i , a transition is possible to state s_k^v of subset S_k by the failure of a component, then the state s_k^v and all the states generated from s_k^v by the downward transitions will be common to both S_i and S_k . The two subsets will not therefore remain mutually exclusive. Reasoning backwards, there cannot be transitions between two mutually exclusive subsets equivalent to two minimal cut sets. In such a case the frequency contribution due to S_i and S_k is $f_i + f_k$. In practice, however, the state space subsets representing minimal cutsets overlap and the frequency formula for this case can be derived by referring to the Venn diagram in Fig. 4.11.

Let

$$S_i = A_1 + A_2$$

and

$$S_k = A_3 + A_2$$

so that

$$S_i \cap S_k = A_2$$

The frequency of encountering the subset $S_i \cup S_k$ is given by

$$f(S_i \cup S_k) = P(A_1)\bar{\mu}_i + P(A_3)\bar{\mu}_k + P(A_2)(\bar{\mu}_i \cap \bar{\mu}_k) \quad (4.12)$$

where

$$\bar{\mu}_i = \sum_{j \in C_i} \mu_j$$

$$\bar{\mu}_k = \sum_{j \in C_k} \mu_j$$

and

$$\bar{\mu}_i \cap \bar{\mu}_k = \sum_{j \in C_i \cap C_k} \mu_j$$

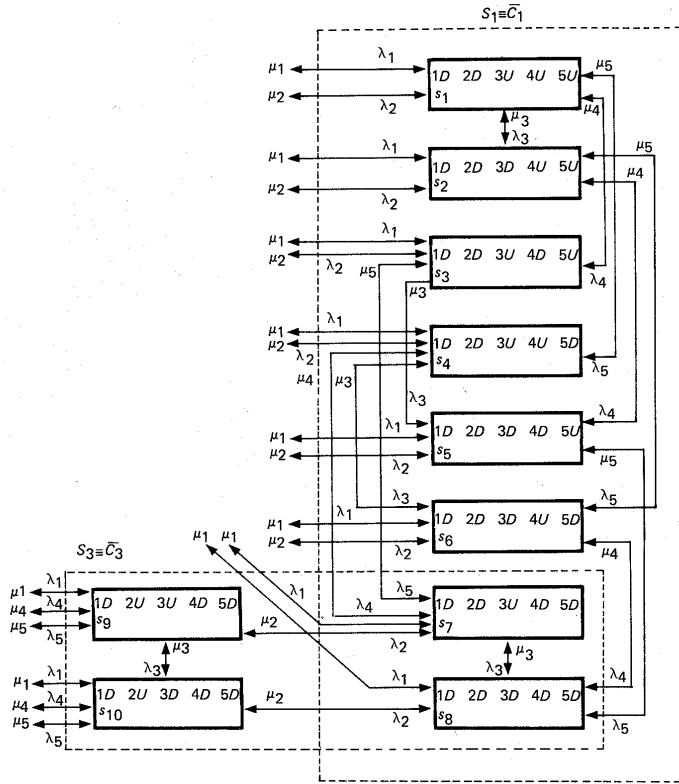

Fig. 4.10 The equivalence between minimal cut sets and state space representations

That is $\bar{\mu}_i \cap \bar{\mu}_k$ represents the summation of the repair rates of the components common to both minimal cut sets. For example for C_1 and C_3 , $\bar{\mu}_1 \cap \bar{\mu}_3 = \mu_1$ since only component 1 is common to both cut sets.

Equation (4.12) can be written as

$$\begin{aligned}
 f(S_i \cup S_k) &= P(A_1 + A_2)\bar{\mu}_i + P(A_3 + A_2)\bar{\mu}_k + P(A_2)(\bar{\mu}_i \cap \bar{\mu}_k) \\
 &\quad - P(A_2)\bar{\mu}_i - P(A_2)\bar{\mu}_k \\
 &= P(S_i)\bar{\mu}_i + P(S_k)\bar{\mu}_k - P(S_i \cap S_k)(\bar{\mu}_i + \bar{\mu}_k - \bar{\mu}_i \cap \bar{\mu}_k) \\
 &= P(S_i)\bar{\mu}_i + P(S_k)\bar{\mu}_k - P(S_i \cap S_k)(\bar{\mu}_i \cup \bar{\mu}_k) \\
 &= f(S_i) + f(S_k) - f(S_i \cap S_k) \tag{4.13} \\
 &= P(\bar{C}_i)\bar{\mu}_i + P(\bar{C}_k)\bar{\mu}_k - P(\bar{C}_i \cap \bar{C}_k)(\bar{\mu}_i \cup \bar{\mu}_k) \tag{4.14}
 \end{aligned}$$

In the above expression $\bar{\mu}_i \cup \bar{\mu}_k$ is the summation of the repair rates of the components which belong either to C_i or to C_k or to both i.e.

$$\bar{\mu}_i \cup \bar{\mu}_k = \sum_{j \in C_i \cup C_k} \mu_j$$

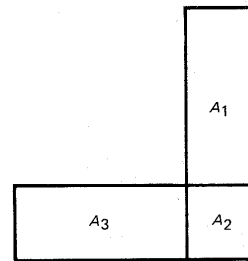

Fig. 4.11 Venn diagram for overlapping subsets representing two minimal cut sets

Equations (4.13) and (4.14) can be extended to the union of three subsets representing three minimal cut sets as follows

$$\begin{aligned}
 f(S_i \cup S_k \cup S_j) &= f(S_i \cup S_k) + f(S_j) - f((S_i \cup S_k) \cap S_j) \\
 &= f(S_i) + f(S_k) - f(S_i \cap S_k) + f(S_j) \\
 &\quad - f((S_i \cap S_j) \cup (S_k \cap S_j))
 \end{aligned}$$

$$\begin{aligned}
 &= f(S_i) + f(S_k) + f(S_i) - f(S_i \cap S_k) \\
 &\quad - [f(S_i \cap S_i) + f(S_k \cap S_i) - f(S_i \cap S_k \cap S_i)] \\
 &= f(S_i) + f(S_k) + f(S_i) \\
 &\quad - [f(S_i \cap S_k) + f(S_i \cap S_i) + f(S_k \cap S_i)] \\
 &\quad + f(S_i \cap S_k \cap S_i) \\
 &= P(\bar{C}_i)\bar{\mu}_i + P(\bar{C}_k)\bar{\mu}_k + P(\bar{C}_i)\bar{\mu}_i \\
 &\quad - [P(\bar{C}_i \cap \bar{C}_k)(\bar{\mu}_i \cup \bar{\mu}_k) + P(\bar{C}_k \cap \bar{C}_i)(\bar{\mu}_k \cup \bar{\mu}_i)] \\
 &\quad + P(\bar{C}_i \cap \bar{C}_i)(\bar{\mu}_i \cup \bar{\mu}_i) \\
 &\quad + P(\bar{C}_i \cap \bar{C}_k \cap \bar{C}_i)(\bar{\mu}_i \cup \bar{\mu}_k \cup \bar{\mu}_i)
 \end{aligned}$$

where as before $\bar{\mu}_i \cup \bar{\mu}_k \cup \bar{\mu}_i$ is the summation of the repair rates of components which belong to any or all of the minimal cut sets C_i, C_k and C_l . Proceeding in the above manner, the formula can be extended to the general case of m cut sets

$$\begin{aligned}
 f_f &= f(S_1 \cup S_2 \cup S_3 \cup \dots \cup S_m) \\
 &= [P(\bar{C}_1)\bar{\mu}_1 + P(\bar{C}_2)\bar{\mu}_2 + \dots + P(\bar{C}_m)\bar{\mu}_m] \leftarrow \binom{m}{1} \text{ terms order 1} \\
 &\quad - [P(\bar{C}_1 \cap \bar{C}_2)(\bar{\mu}_1 \cup \bar{\mu}_2) + P(\bar{C}_1 \cap \bar{C}_3)(\bar{\mu}_1 \cup \bar{\mu}_3) + \dots \\
 &\quad + P(\bar{C}_i \cap \bar{C}_j)(\bar{\mu}_i \cup \bar{\mu}_j)] \leftarrow \binom{m}{2} \text{ terms order 2} \\
 &\quad + [P(\bar{C}_1 \cap \bar{C}_2 \cap \bar{C}_3)(\bar{\mu}_1 \cup \bar{\mu}_2 \cup \bar{\mu}_3) + \dots \\
 &\quad + P(\bar{C}_i \cap \bar{C}_j \cap \bar{C}_k)(\bar{\mu}_i \cup \bar{\mu}_j \cup \bar{\mu}_k)] \leftarrow \binom{m}{3} \text{ terms order 3} \\
 &\quad \dots \dots \dots \\
 &\quad (-1)^{m-1} [P(\bar{C}_1 \cap \bar{C}_2 \cap \bar{C}_3 \cap \dots \cap \bar{C}_m) \\
 &\quad \times (\bar{\mu}_1 \cup \bar{\mu}_2 \cup \bar{\mu}_3 \cup \dots \cup \bar{\mu}_m)] \quad \text{order } m
 \end{aligned} \tag{4.15}$$

The calculation of the terms of the above expansion involves simple multiplications and additions. The contribution by terms beyond the third or

fourth order is quite insignificant and the calculations can be suitably truncated. In high reliability systems the first row alone gives good results

i.e.

$$f_{U1} \simeq \sum_{\forall i} P(\bar{C}_i)\bar{\mu}_i$$

This equation gives the upper bound approximation for the frequency of system failure. The lower bound to the frequency is

$$f_{L1} = f_{U1} - \sum_{i < k} P(\bar{C}_i \cap \bar{C}_k)(\bar{\mu}_i + \bar{\mu}_k).$$

f_{U1} and f_{L1} are the first upper and lower bounds to the approximation of f_f given by Equation (4.15). Successively closer alternating bounds can be obtained by the additions of odd and even order terms. The computation can be truncated when the margin between upper and lower bounds becomes negligible.

The use of the cut set manipulation equations can be illustrated by application to the network of Fig. 4.8. The minimal cuts for it have already been enumerated in Table 4.1. All the components are assumed identical each having λ and μ as the failure and repair rates. The probability of component failure

$$P_d = \frac{\lambda}{\lambda + \mu}$$

The expression for probability of system failure is

$$\begin{aligned}
 P_f &= P(\bar{C}_1 \cup \bar{C}_2 \cup \bar{C}_3 \cup \bar{C}_4) \\
 &= [P(\bar{C}_1) + P(\bar{C}_2) + P(\bar{C}_3) + P(\bar{C}_4)] \\
 &\quad - [P(\bar{C}_1 \cap \bar{C}_2) + P(\bar{C}_1 \cap \bar{C}_3) + P(\bar{C}_1 \cap \bar{C}_4) + P(\bar{C}_2 \cap \bar{C}_3) \\
 &\quad + P(\bar{C}_3 \cap \bar{C}_4) + P(\bar{C}_2 \cap \bar{C}_4)] \\
 &\quad + [P(\bar{C}_1 \cap \bar{C}_2 \cap \bar{C}_3) + P(\bar{C}_1 \cap \bar{C}_2 \cap \bar{C}_4) + P(\bar{C}_2 \cap \bar{C}_3 \cap \bar{C}_4) \\
 &\quad + P(\bar{C}_1 \cap \bar{C}_3 \cap \bar{C}_4)] - [P(\bar{C}_1 \cap \bar{C}_2 \cap \bar{C}_3 \cap \bar{C}_4)]
 \end{aligned}$$

The various terms are evaluated below

$$\begin{aligned}
 P(\bar{C}_1) &= P(\bar{C}_2) = (p_d)^2 \\
 P(\bar{C}_3) &= P(\bar{C}_4) = (p_d)^3 \\
 P(\bar{C}_1 \cap \bar{C}_2) &= P(\bar{C}_1 \cap \bar{C}_3) = P(\bar{C}_1 \cap \bar{C}_4) = P(\bar{C}_2 \cap \bar{C}_3) \\
 &= P(\bar{C}_2 \cap \bar{C}_4) = (p_d)^4
 \end{aligned}$$

$$\begin{aligned}
P(\bar{C}_3 \cap \bar{C}_4) &= (p_d)^5 \\
P(\bar{C}_1 \cap \bar{C}_2 \cap \bar{C}_3) &= P(\bar{C}_1 \cap \bar{C}_2 \cap \bar{C}_4) = P(\bar{C}_2 \cap \bar{C}_3 \cap \bar{C}_4) \\
&= P(\bar{C}_1 \cap \bar{C}_3 \cap \bar{C}_4) = (p_d)^5 \\
P(\bar{C}_1 \cap \bar{C}_2 \cap \bar{C}_3 \cap \bar{C}_4) &= (p_d)^5
\end{aligned}$$

Substituting these values

$$P_f = 2p_d^2 + 2p_d^3 - 5p_d^4 + 2p_d^5$$

Calculation of frequency of failure.

The formula for failure frequency can be written as

$$\begin{aligned}
f_f &= [P(\bar{C}_1)\bar{\mu}_1 + P(\bar{C}_2)\bar{\mu}_2 + P(\bar{C}_3)\bar{\mu}_3 + P(\bar{C}_4)\bar{\mu}_4] \\
&\quad - [P(\bar{C}_1 \cap \bar{C}_2)(\bar{\mu}_1 \cup \bar{\mu}_2) + P(\bar{C}_1 \cap \bar{C}_3)(\bar{\mu}_1 \cup \bar{\mu}_3) \\
&\quad + P(\bar{C}_1 \cap \bar{C}_4)(\bar{\mu}_1 \cup \bar{\mu}_4) + P(\bar{C}_2 \cap \bar{C}_3)(\bar{\mu}_2 \cup \bar{\mu}_3) \\
&\quad + P(\bar{C}_3 \cap \bar{C}_4)(\bar{\mu}_3 \cup \bar{\mu}_4) + P(\bar{C}_2 \cap \bar{C}_4)(\bar{\mu}_2 \cup \bar{\mu}_4)] \\
&\quad + [P(\bar{C}_1 \cap \bar{C}_2 \cap \bar{C}_3)(\bar{\mu}_1 \cup \bar{\mu}_2 \cup \bar{\mu}_3) \\
&\quad + P(\bar{C}_1 \cap \bar{C}_2 \cap \bar{C}_4)(\bar{\mu}_1 \cup \bar{\mu}_2 \cup \bar{\mu}_4) \\
&\quad + P(\bar{C}_2 \cap \bar{C}_3 \cap \bar{C}_4)(\bar{\mu}_2 \cup \bar{\mu}_3 \cup \bar{\mu}_4) \\
&\quad + P(\bar{C}_1 \cap \bar{C}_3 \cap \bar{C}_4)(\bar{\mu}_1 \cup \bar{\mu}_3 \cup \bar{\mu}_4)] \\
&\quad - [P(\bar{C}_1 \cap \bar{C}_2 \cap \bar{C}_3 \cap \bar{C}_4)] (\bar{\mu}_1 \cup \bar{\mu}_2 \cup \bar{\mu}_3 \cup \bar{\mu}_4)
\end{aligned}$$

Now

$$\bar{\mu}_1 = \bar{\mu}_2 = 2\mu$$

$$\bar{\mu}_3 = \bar{\mu}_4 = 3\mu$$

$$\bar{\mu}_1 \cup \bar{\mu}_2 = \bar{\mu}_1 \cup \bar{\mu}_3 = \bar{\mu}_1 \cup \bar{\mu}_4 = \bar{\mu}_2 \cup \bar{\mu}_3 = \bar{\mu}_2 \cup \bar{\mu}_4 = 4\mu$$

$$\bar{\mu}_3 \cup \bar{\mu}_4 = 5\mu$$

$$\bar{\mu}_1 \cup \bar{\mu}_2 \cup \bar{\mu}_3 = \bar{\mu}_1 \cup \bar{\mu}_2 \cup \bar{\mu}_4 = \bar{\mu}_2 \cup \bar{\mu}_3 \cup \bar{\mu}_4 = \bar{\mu}_1 \cup \bar{\mu}_3 \cup \bar{\mu}_4 = 5\mu$$

and

$$\bar{\mu}_1 \cup \bar{\mu}_2 \cup \bar{\mu}_3 \cup \bar{\mu}_4 = 5\mu$$

Substituting these values

$$f_f = (4p_d^2 + 6p_d^3 - 20p_d^4 + 10p_d^5)\mu$$

The numerical values were obtained by keeping μ equal to 438 repairs per year, i.e. a mean down time of the component equal to 20 hours, and varying the failure rate from two failures per year to 219 failures per year. These results are shown in Table 4.2. The purpose of this study is to show the difference between exact and upper bound approximate results as a function of the component reliability. It can be seen that when component reliability is close to unity, the upper bound approximations gives almost exact results.

Algorithm to Determine Minimal Cut Sets

When the reliability block diagram is small, the set of minimal cuts can be found by visual examination. In a large network such an examination could be very laborious and perhaps even impossible. Reference 3 describes an algorithm for generating the minimal cuts of a network. This procedure is quite suitable for computer application.

The input or supply node of a reliability block diagram will be denoted by s and the output or the load node by l . The removal of the components in a minimal cut separates the network into exactly two connected subnetworks, one containing the node s and the other node l . The minimal cut in other words partitions the set N of all nodes into subsets N^+ and N^- . The set N^+ defines a connected subnetwork that includes s and N^- defines another connected subnetwork that includes l .

The algorithm generates a tree of the network, the vertices being the points and the edges being the line segments on the tree. The tree starts from the root vertex denoted by 0. The edges are marked n^+ or n^- . The symbol n^+ means that the node n of the reliability diagram is a member of N^+ and n^- means that node n of reliability diagram is a member of N^- . With each node i of the tree are associated four subsets of the nodes of the reliability diagram, X_{1i} , X_{2i} , X_{3i} and W_i . Let h_i be the unique simple path connecting vertex i to the root vertex, then

Node $n \in X_{1i}$ if an edge in the path h_i is labelled n^+

Node $n \in X_{2i}$ if an edge in the path h_i is labelled n^-

Node $n \in X_{3i}$ if it is neither in X_{1i} nor in X_{2i} but is a member of N .

Node $n \in W_i$ if it is in X_{3i} and if it is the terminal of a component whose other terminal is a member of X_{1i}

Table 4.2 Probabilities and frequencies of failure for the system in Fig. 4.8

λ failures per year	Component Reliability	Probability of Failure		Frequency of Failure	
		Exact	Under Bound Approximately	Exact	Under Bound Approximately
2-0	0.995455	$4150801221 \times 10^{-4}$	$4151014274 \times 10^{-4}$	$3644142301 \times 10^{-1}$	364451540×10^{-1}
4-0	0.990950	$1652457187 \times 10^{-3}$	$1652791341 \times 10^{-3}$	1453752889	1454337779
8-0	0.982063	$6545162018 \times 10^{-3}$	$6550300836 \times 10^{-3}$	5779632215	578861915
16-0	0.964758	$2563976981 \times 10^{-2}$	$2571581307 \times 10^{-2}$	227773988×10^1	22910491×10^1
32-0	0.9319149	$9797874590 \times 10^{-2}$	$9902391570 \times 10^{-2}$	8769140832×10^1	895097294×10^1
219-0	0.6666667	2427983539	2962962962	2018765432×10^3	2920000000×10^3

$\mu = 438.0$ repairs/year

The algorithm now proceeds as follows:

Step 1: Generate vertices 0, 1 and 2 and label the edges (0, 1) and (1, 2) as s^+ and 1^- respectively. This means that for all minimal cuts s and 1 are members of N^+ and N^- respectively. The vertices 0 and 1 are assumed scanned but vertex 2 is unscanned. Go to step 2.

Step 2: If there are no unscanned vertices, the complete tree has been generated and the algorithm terminates. Otherwise, choose the unscanned vertex with the greatest index and mark it scanned and let it be called i . Find the unique simple path h_i from i to the root vertex 0, and identify the subsets X_{1i} , X_{2i} , X_{3i} and W_i as defined above. If W_i is null, i.e. has no member go to step 7, otherwise choose x , an element of W_i and construct the subnetwork defined by the set of nodes $X_4 = X_{2i} \cup X_{3i} - x$. If this subnetwork is connected, go to step 3, and if not go to step 4.

Step 3: Generate two new vertices k and $k+1$ where k is one greater than the highest index so far in the tree. Create edges (i, k) and $(i, k+1)$ and label them x^+ and x^- . The vertices k and $k+1$ are unscanned vertices. Go to step 2.

Step 4: Find the set of nodes X_5 which defines a connected subnetwork that includes 1. If X_{2i} is a subset of X_5 go to step 5, otherwise to step 6.

Step 5: Generate vertex k and edge (i, k) labelled x^+ . Determine the set $X_6 = X_4 - X_5$. If $|X_6|$ is the number of the elements of X_6 , then create vertices $k+1, k, \dots, k+|X_6|$ and generate edges $(k, k+1), (k+1, k+2), \dots, (k+|X_6|-1, k+|X_6|)$ and label them Z^+ where $Z \in X_6$. Finally generate vertex $k+|X_6|+1$ and create edge $(i, k+|X_6|+1)$ labelled x^- . Go to step 2.

Step 6: Generate one new vertex index k and create the edge (i, k) labelled x^- . Go to step 2.

Step 7: At this step a minimal cut has been generated. The set $N_i^+ = X_{1i}$ and $N_i^- = N - X_{1i}$. The components whose one terminal is in N_i^+ and the other in N_i^- are the members of the minimal cut. Go to step 2 to create other minimal cuts.

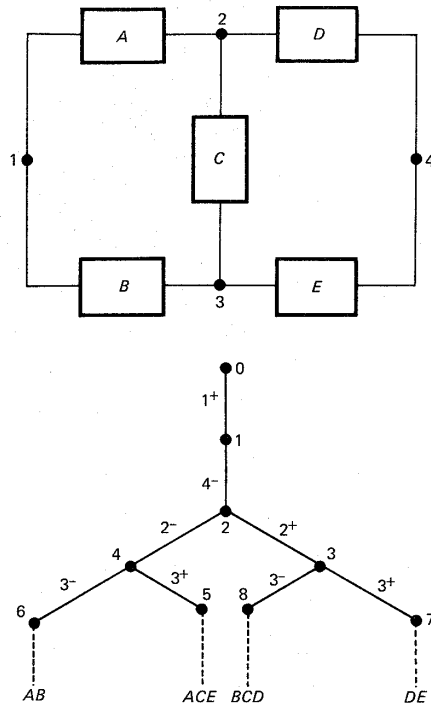
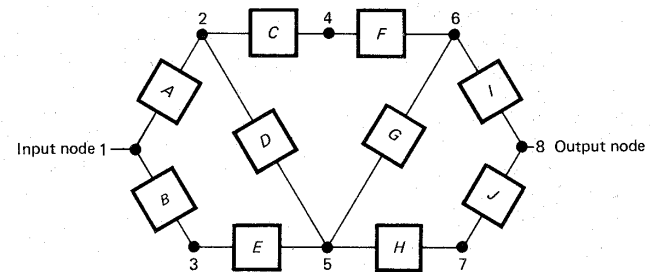

Fig. 4.12 The minimal cut generation tree

The above algorithm is illustrated by application to the reliability block diagram of Fig. 4.8. As the nodes are to be marked by integers the components may be represented by letters as shown in Fig. 4.12 which shows the tree for this network. The reader is urged to verify this tree by going through the different steps of the algorithm.

Exercises

1. Calculate the probability and frequency of system failure in Example 4.2 using the state space approach.
2. Enumerate the minimal cut sets for the following reliability block diagram.



References

1. R. Billinton and C. Singh, Generating Capacity Reliability Evaluation in Interconnected Systems Using a Frequency and Duration Approach—Part I. Mathematical Analysis, *IEEE Trans., Power App. and Systems* (July/August 1971).
2. J.A. Buzacott, Network Approaches to Finding the Reliability of Repairable Systems, *IEEE Trans. on Reliability*, R-19, 4 (November 1970).
3. P.A. Jenson and M. Bellmore, An Algorithm to Determine the Reliability of a Complex Systems, *IEEE Trans. on Reliability*, R-18, 4 (November 1969).
4. C. Singh and R. Billinton, A New Method to Determine the Failure Frequency of a Complex System, *Micro-Electronics and Reliability*, Vol. 12, No. 5 (1973).
5. C. Singh, 'Reliability Modelling and Evaluation in Electric Power Systems', Ph.D. Thesis, University of Saskatchewan, Saskatoon, Canada (August 1972).
6. L.M. Shooman, *Probabilistic Reliability*, New York, McGraw-Hill (1968).